



AIR TORQUE

COMPANY PROFILE

CATALOGUE

ALUMINIUM ACTUATOR RANGE



<https://gidroterm-prom.com.ua/>
044-333-67-80 ; 067-435-61-80
050-153-61-80
e-mail: gidroterm.prom@gmail.com

Founded in 1990, Air Torque Spa has become in few years one of the worldwide leading manufacturer of rack and pinion pneumatic actuators.

Since the beginning the mission of the Air Torque Spa has been always to offer innovative products by combining the long filed experience as market leader, the innovational spirit, the well-known reliability in actuator designing and the high quality manufacturing level supported by high level Western Europe components suppliers, and based on an ISO 9000-2008 quality system.



With the attitude to always satisfy the market and customers needs, Air Torque Spa has developed the worldwide widest range of aluminium alloy rack and pinion actuators with torques up to 10.000 Nm and available with different options in terms of valve interfaces, surface protection levels and smart functional features; all covered by several International Patents.

Air Torque Spa has integrated its production of standard actuators with special actuators like 120°, 135° and 180° rotation both double acting and spring returns; 3 position actuators both 90° and 180° rotation, fast acting actuators and hydraulic dampered actuators. A line of rack and pinion stainless steel actuators completes the range of Air Torque Spa lines of products.

Air Torque Spa factory counts nowadays 50 employers on an extension of 5000 square meters, with a yearly production of more than 300.000 actuators.

The sales are covering all the world, from the Americas to Oceania, through a wide network of official distributors, directly to big end-users and directly to big OEM customers.

RANGE

Product Lines	Range
<p>4th Generation Line "Upgrade" Series</p> 	<p>17 sizes available with torques up to 10.000 Nm in double acting and up to 4068 Nm for the spring return version, available in 6 different protection levels. Working temperature from -55°C and up to +150°C (Standard from -40°C up to +80°C).</p>
<p>Power Technology Line "B" Series</p> 	<p>17 sizes available with torques up to 10.000 Nm in double acting and up to 4068 Nm for the spring return version, available in 6 different protection levels. Working temperature from -55°C and up to +150°C (Standard from -40°C up to +80°C).</p>
<p>Stainless Steel Line "S" Series</p> 	<p>9 sizes available with torques up to 1966 Nm in double acting and up to 865 Nm for the spring return version. Working temperature from -55°C and up to +150°C (Standard from -40°C up to +80°C).</p>

ALUMINIUM ACTUATOR RANGE

AIR TORQUE
Product Range

DOUBLE ACTING

from 13,2 Nm to 10.000 Nm at 6 bar

100% travel stop limitation



Lock-out capability



DOUBLE ACTING
90° rotation



DOUBLE ACTING
120° rotation



DOUBLE ACTING
135° rotation



DOUBLE ACTING
180° rotation



3 Position actuator
90° rotation



FAST ACTING



Hydraulic Damper



3 Position actuator
180° rotation



SPRING RETURN

from 8,1 Nm to 4068 Nm with 12 springs

100% travel stop limitation



Lock-out capability



SPRING RETURN
90° rotation



SPRING RETURN
120° rotation



SPRING RETURN
180° rotation



3 Position actuator
90° rotation



FAST ACTING



Hydraulic Damper



FAIL MID
180° rotation



FIELDS OF APPLICATION

CHEMICAL	FOOD INDUSTRY	NAVAL
PHARMACEUTICAL	PULP & PAPER	CAR INDUSTRY
REFINERY	WATER TREATMENT	STEEL PLANT

REFERENCES

AALBORG INDUSTRIES	OEGUSSA-EVONIK	LINDE GAS	SAMSUNG TOTAL
AIR LIQUIDE	OUPONT	NESTE OIL	SK ENERGY
AKZONOBEL	ENI	NESTLE	SOLVAY
AURAMARINE	FLSMIDTH	NOVARTIS	TECHNIMONT
BASF	HALTON MARINE	POSCO	THE OOW CHEMICAL COMPANY
BAYER	HYUNDAI HEAVY INDUSTRY	PRAXAIR	TRACTEBEL
CHEMINOVA	JONHSON CONTROLS	REPSOL	VOPAK
DAEWOO SHIPBUILDING	LG PETRO CHEMICAL	SAMSUNG PETRO CHEMICAL	WÄRTSILÄ

CERTIFICATIONS

The image displays a collection of certification documents for Air Torque S.p.A. Key certifications include:

- ISO 9001-2008**: Certificate of Approval for the Quality Management System.
- SIL3 IEC 61508**: Safety-related certification.
- ATEX 94/9/EC**: Certification for explosive atmospheres.
- Type Approval**: Various technical approvals.
- INERIS**: Safety certification.
- SKE VERITAS**: Safety Certificate.
- GOST-R** and **GOST Rostekhnadzor**: Russian standards certifications.
- EN 60529 IEC 529**: Certification for protection against ingress of solids and liquids.
- Nemko**: Certification for product safety.
- Technical Report**: Report 03-1-02 for a pneumatic actuator.



The 4th Generation Line pneumatic actuators, Upgrade Series, are the result of the Air Torque mission to offer always innovative products by combining the long field experience as market leader, the innovational spirit, the well-known reliability in actuator designing and the high quality manufacturing level.

The Air Torque experience has produced the following main key features included in the 4th Generation Line, *Upgrade Series*:

Reliable and flexible solutions

By combining high quality products, field and design experience, Air Torque is able to satisfy all the customers and market expectations by offering reliable, flexible and customized solutions together with a qualified service.

Innovative Patented Design

The new technical features developed and incorporated in the 4th Generation Line pneumatic actuators, *Upgrade Series*, permit to have the best product versatility for an easier and easier valve automation. The Upgrade Series are covered by five International patents.

The most complete range and options

The *Upgrade Series* pneumatic actuators are available in:

- Eighteen models
- Spring return and double acting versions
- Torque up to 10.000 Nm
- Six different protection levels
- Low and high temperature constructions
- Large availability of many ISO flanges and drive shaft connections for direct valve automation
- 120°-135°-180° rotation both in double acting and spring return
- 180° spring return Fail-Mid
- 3 Position actuators, 90° and 180° rotation, both double acting and spring return versions
- Fast acting actuators
- Hydraulic damper actuators

High quality level production

The 4th Generation Line pneumatic actuators, *Upgrade Series*, have been designed and tested to obtain the highest cycling life and the most reliable performance with very reduced maintenance and service.

International Standard

The 4th Generation Line pneumatic actuators, *Upgrade Series*, have been designed, manufactured and tested in full compliance with all the applicable International standards.

Technology and material

The 4th Generation Line pneumatic actuators, *Upgrade Series*, are manufactured with the highest material quality, the most accurate material selections and the latest production technologies.



TECHNICAL FEATURES

1. Alodur hard anodized body

Extruded aluminum body with Alodur special hard anodization applied internally and externally for a complete corrosion protection, a lower friction coefficient and an increased surface hardness for the longest wearing resistance.

Many additional protective coatings are available on the external surface for different environmental working conditions.

2. Pistons design

Dual piston rack and pinion design for compact construction, symmetric mounting position, high-cycle life and fast operation, reverse rotation can be accomplished in the field by simply inverting the pistons. Both pistons are anodized for a better corrosion and wearing resistance.

3. Two independent external travel stop adjustments

As a standard, travel stops allowing adjustment for -5° up to $+15^\circ$ on the close position, and for $+5^\circ$ up to -15° on the open position. This allows accurate valve alignment, stroke limitation and provides on actuator a large travel adjustment.

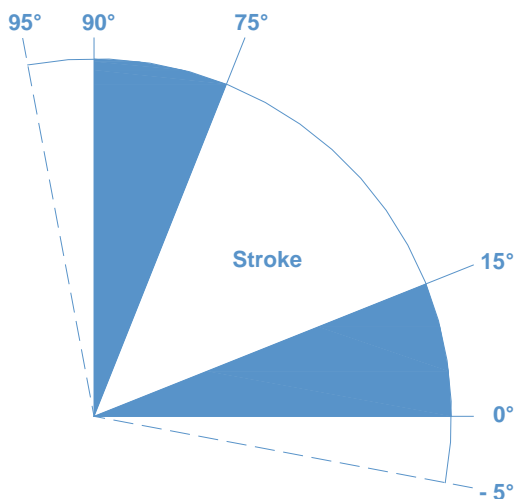

4. Universal and anti-blowout drive shaft

It permits an easy conversion from parallel to diagonal square and vice versa. It is also available in double square; both solutions permit a lower and more flexible inventory.

5. Drive shaft top adaptor

The aluminum top adaptor for ancillary driving/attachment gives a more precise and stable coupling with ancillary stem suitable for higher temperature application. It is suitable and available both for single (diagonal and parallel) and double square drive shafts.

6. One compact and modern design

With identical body and end caps for double acting and spring return model to reduce inventory, allows field conversion, by adding or removing modular spring cartridge.

7. Position indication

The combination of the new top adaptor and the new position indicators allows to achieve easily the correct actuator/valve position indication by just rotating of 90° the top adaptor and the indicator. This operation can be easily done also on the field by avoiding the actuator disassembling.

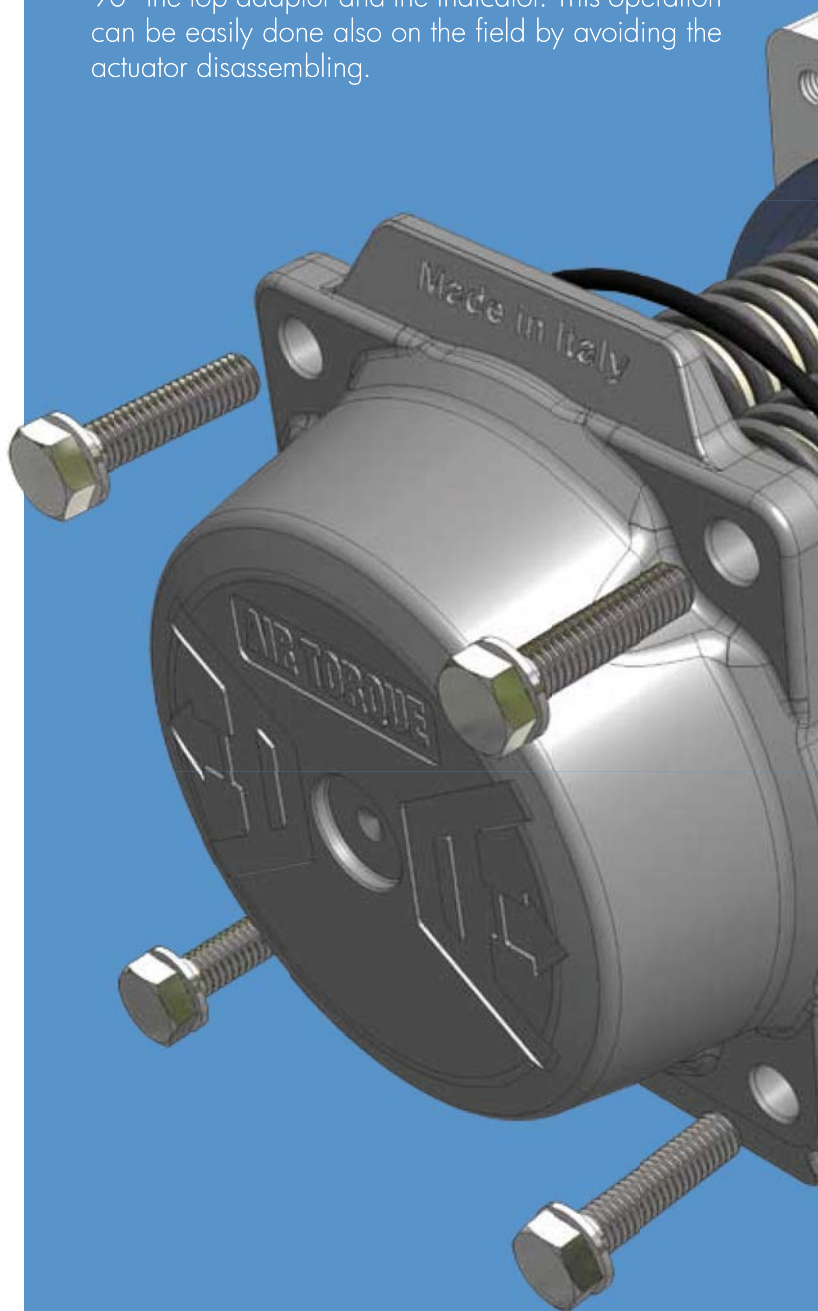

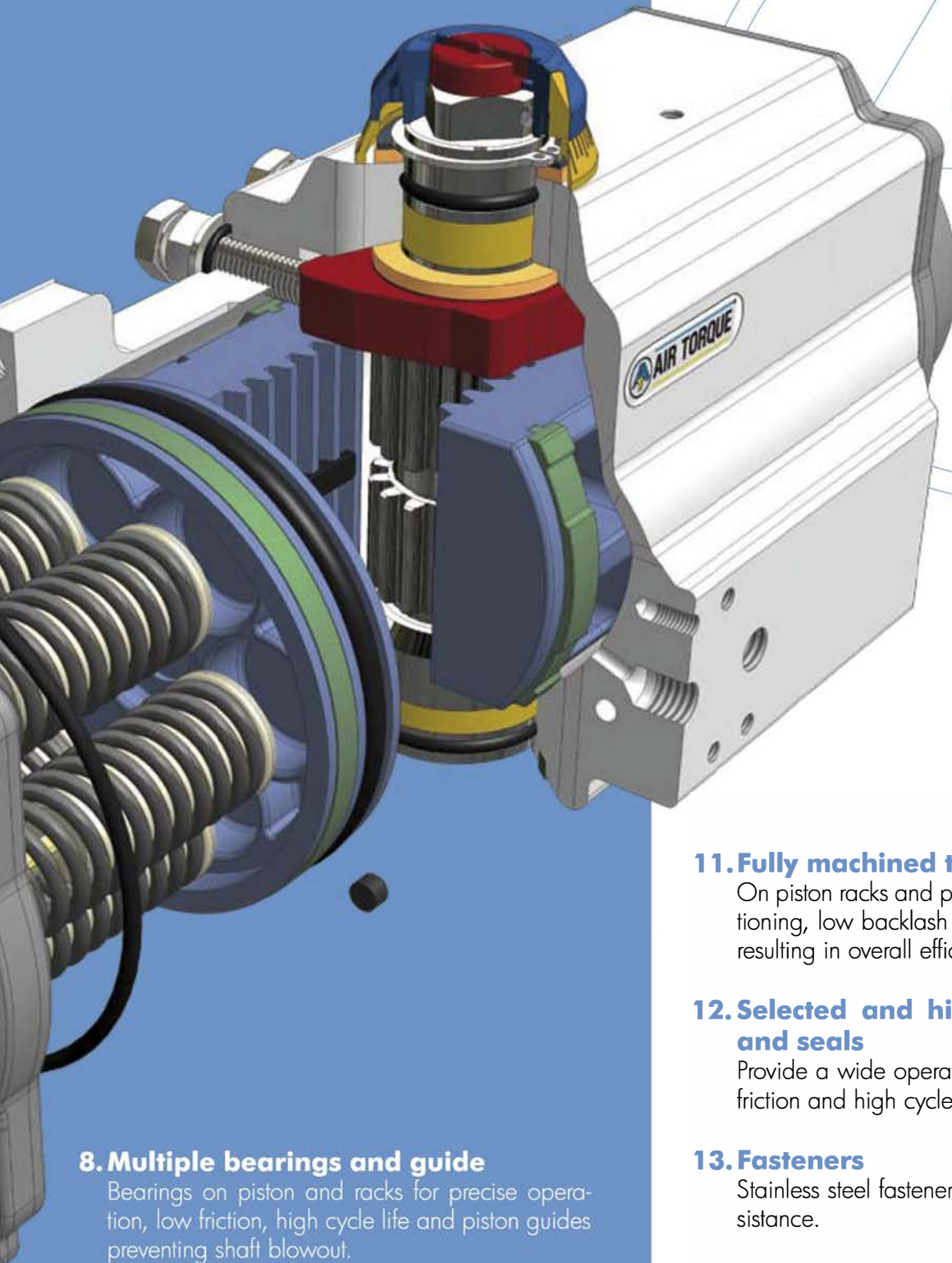

8. Multiple bearings and guide

Bearings on piston and racks for precise operation, low friction, high cycle life and piston guides preventing shaft blowout.

9. Modular preloaded springs

Cartridge design in high grade coated steel for simple range versatility, greater safety and corrosion resistance.

10. Electroless nickel-plated drive-shaft

Blow-out proof, bearing guided for improved safety and maximum cycle life.

11. Fully machined teeth

On piston racks and pinion shaft for accurate positioning, low backlash and maximum engagement resulting in overall efficient operation.

12. Selected and high quality bearings and seals

Provide a wide operating temperature range, low friction and high cycle life.

13. Fasteners

Stainless steel fasteners for long term corrosion resistance.

14. Full compliance

To specifications ISO 5211, DIN 3337 and VDI/VDE 3845 providing the product interchangeability and the easiest valve automation and accessories installation.

15. Product Identity

Plastic insert with Air Torque logo and unique patented design.

PRODUCT RANGE

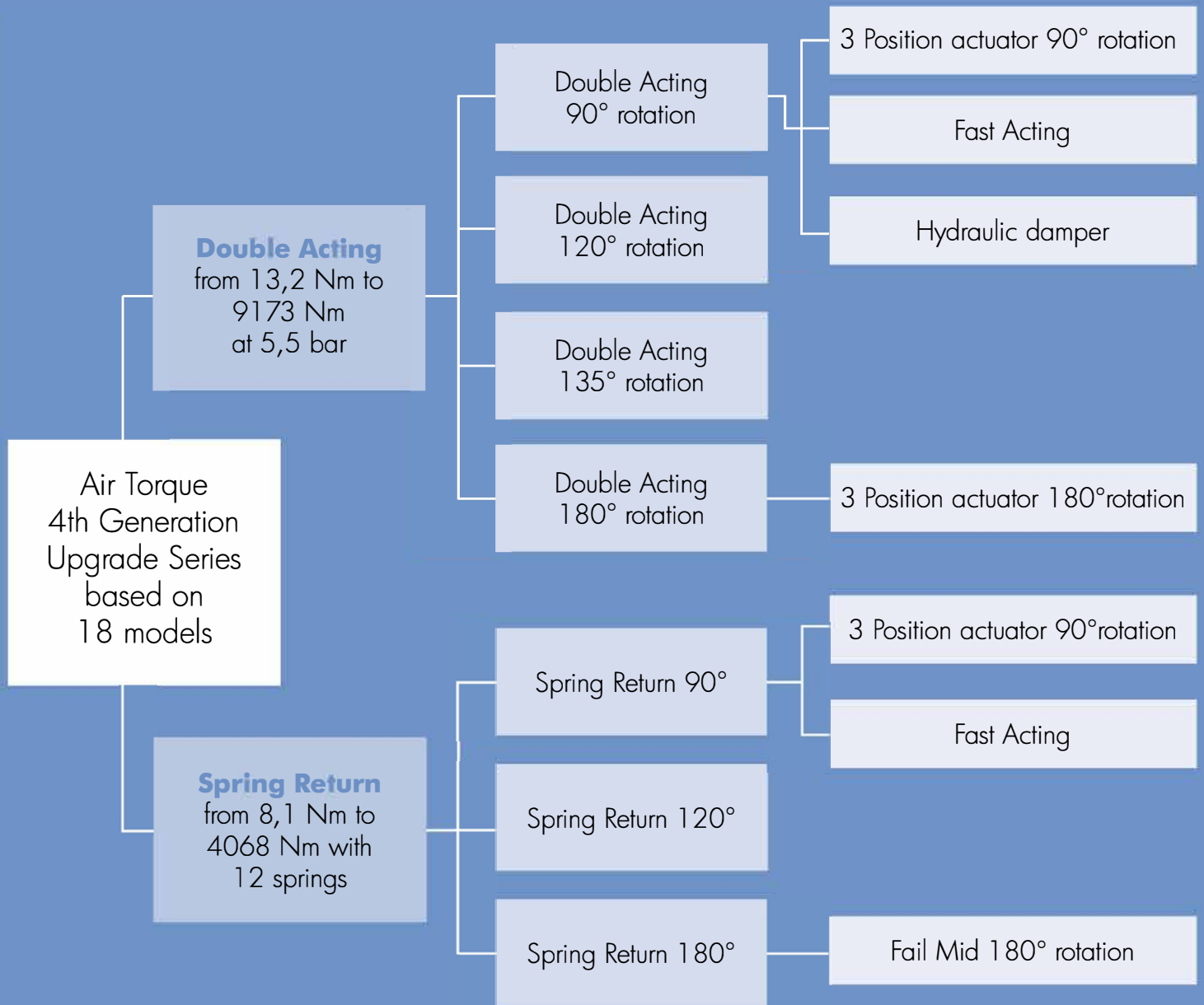

THE PRODUCT RANGE INCLUDES ALSO THE FOLLOWING OPTIONS



LOCK-OUT CAPABILITY

In order to permanently lock the actuator in position, the actuator can be supplied with a special locking device by using a padlock and therefore preventing unwanted operation.



100% TRAVEL STOP LIMITATION

When a stroke of less than 90° is required e.g. 1°, 5°, 10°, 25°, 50°, 70° and the standard adjustment is not suitable, the actuator can be supplied with special bolts in both End-Caps to allow stroke adjustment or limitation from 0° to 90° according to customer requirements.

1. Operating media

Dry or lubricated air, inert/non-corrosive gases provided that they are compatible with the internal actuator parts

2. Supply pressure

For Double Acting and Spring Return actuators the maximum supply pressure is up to 8 bar (116 PSI), the minimum supply pressure is 2.5 bar (36 PSI).

3. Working Temperature

- Standard actuator construction suitable from -40°C (-40°F) to $+80^{\circ}\text{C}$ ($+176^{\circ}\text{F}$)
- High temperature – HT – actuator construction suitable from -15°C ($+5^{\circ}\text{F}$) to $+150^{\circ}\text{C}$ ($+302^{\circ}\text{F}$)
- Extreme low temperature – LLT – actuator construction suitable from -55°C (-67°F) to $+80^{\circ}\text{C}$ ($+176^{\circ}\text{F}$)

4. Lubrication

Actuators are factory lubricated for life under normal operating conditions.

The standard lubricant is suitable for use from -40°C (-40°F) to $+80^{\circ}\text{C}$ ($+176^{\circ}\text{F}$)

5. Installation

Actuator suitable both for indoor and outdoor installation.

6. Protection and Corrosion resistance

Air Torque actuators are available in 6 different protection levels suitable for different environmental conditions. For severe duties select from the protection level table or contact AIR TORQUE.

7. Actuator selection and Marking

To have a correct actuator selection, the operating conditions have to be evaluated and defined; they will be marked on the actuator identification label.

ACTUATOR FUNCTION and ROTATION

The standard actuator rotation is clockwise to close, a counter-clockwise rotation is achieved when port 2 is pressurized. Non standard actuator rotation is counter-clockwise to close, a clockwise rotation is achieved when port 2 is pressurized. See the technical data-sheet for details.

Double Acting operation function (standard rotation) TOP View:

Air supplied to Port 2 forces the pistons towards the actuator end caps, with the exhaust air exiting from Port 4, a counter-clockwise rotation is achieved.

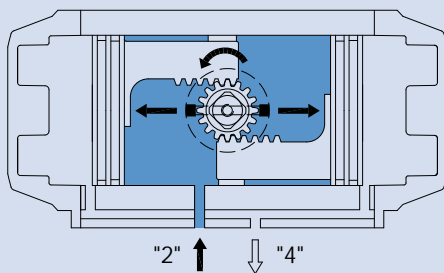

Air supplied to Port 4 forces the pistons inward, exhaust air exits from Port 2, a clockwise rotation is achieved.

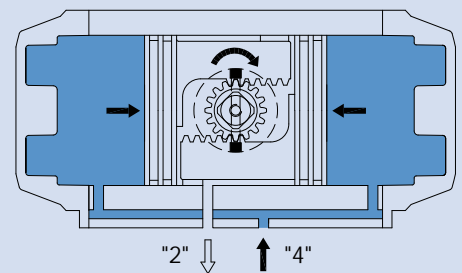

Single Acting operation function (standard rotation) TOP View:

Air supplied to Port 2 forces the pistons toward the actuator end caps, compressing the springs, with the exhaust air exiting from Port 4, a counter clockwise rotation is achieved.

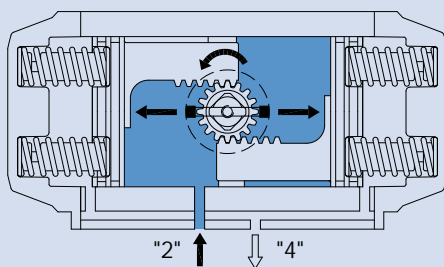

The loss of air pressure (air or electric failure) at Port 2 allows the springs to force the pistons inward with the exhaust air exiting from Port 2, a clockwise rotation is achieved.

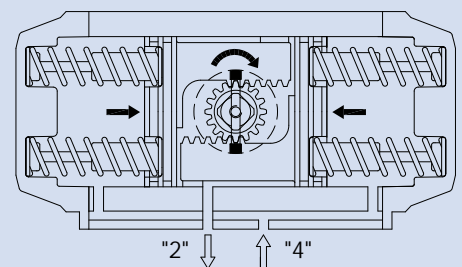

POSITION INDICATOR AND TOP ADAPTOR

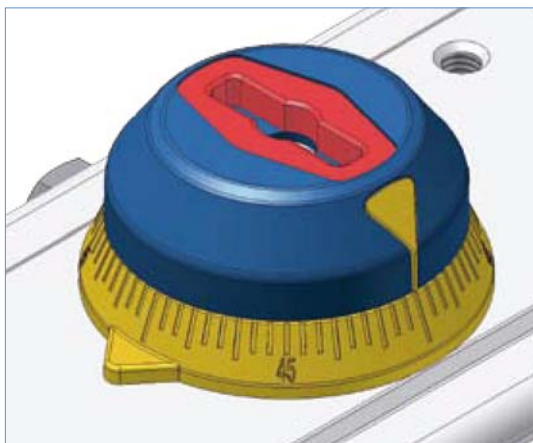

Options available for AT045U and AT101U

Standard position indicator **with stainless steel insert** for ancillary driving/attachment for a more precise and stable coupling with ancillary stem. A graduated ring is fitted, as a standard, under the position indicator in order to have an accurate position indication.

Optional indicators for direct mounting of sensors (P+F, IFM, etc.) and mechanical limit-switches

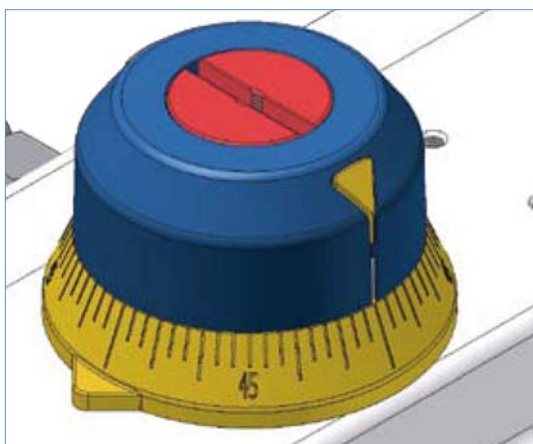
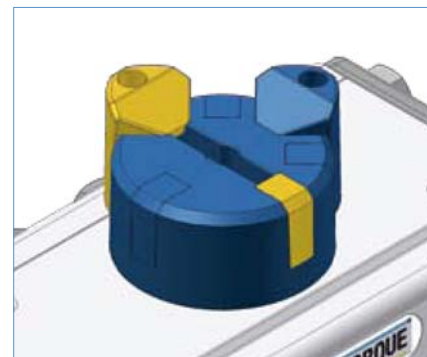
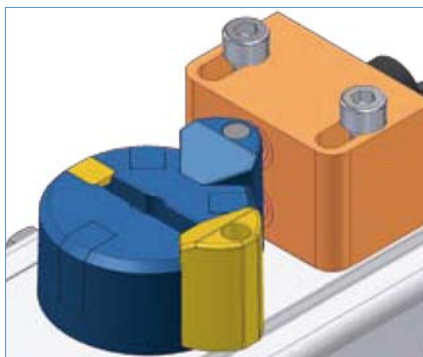
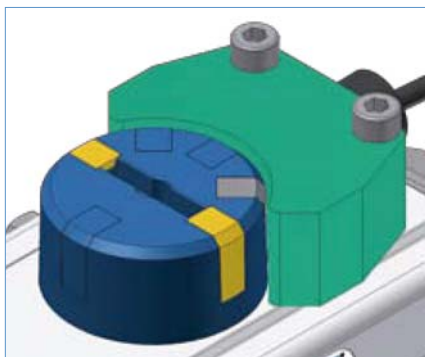

Options available for AT201U and AT1001U

Standard position indicator **with aluminum top adaptor** for ancillary driving/attachment for a more precise and stable coupling with ancillary stem. A graduated ring is fitted, as a standard, under the position indicator in order to have an accurate position indication.

Optional indicators for direct mounting of sensors (P+F, IFM, etc.) and mechanical limit-switches

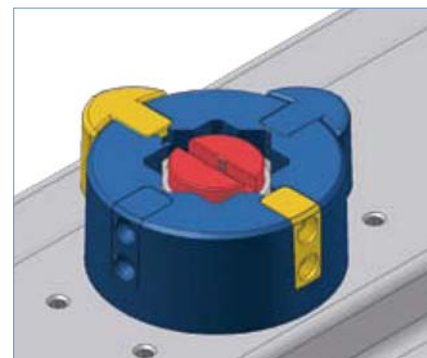
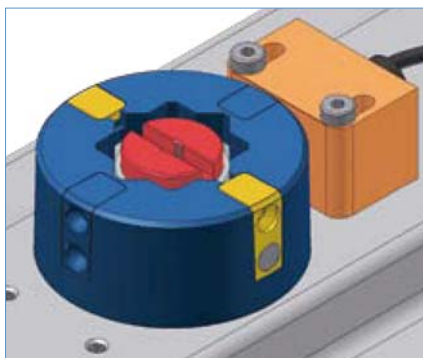
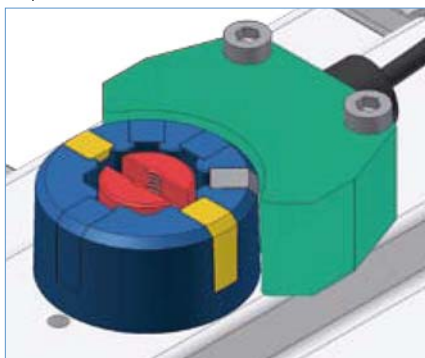

In line and across line actuator installation versatility

The patented design of the top adaptor in combination with the position indicator permits to easily achieve the right actuator/valve position indication since both can be easily fitted in any 45° position. Therefore during the valve automation it is not necessary to reassemble the drive shaft in order to achieve the correct position indication.

The top adaptor is suitable and available for any drive shaft connections like single square (diagonal and parallel), double square, head flat or key head.

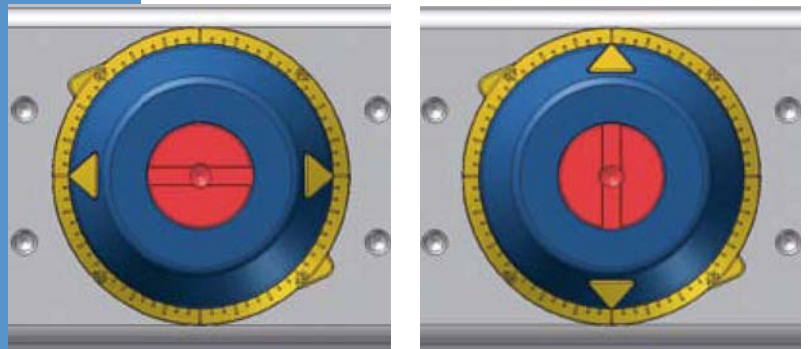
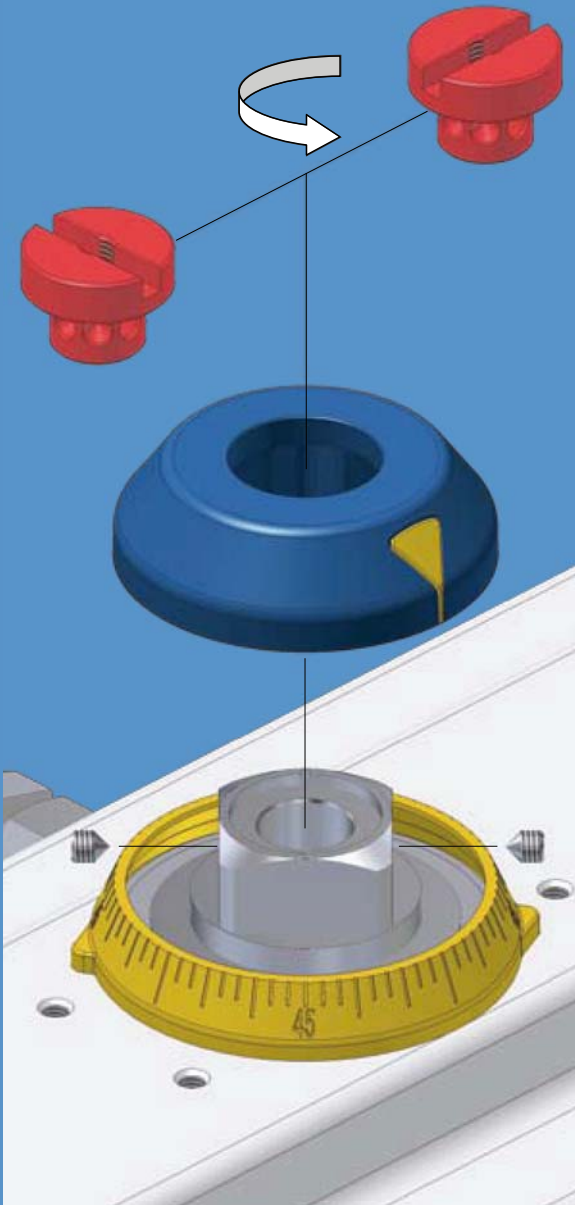

Actuator in close position and IN LINE installation



Actuator in close position and ACROSS LINE installation (Top adaptor and position indicator 90° rotated)



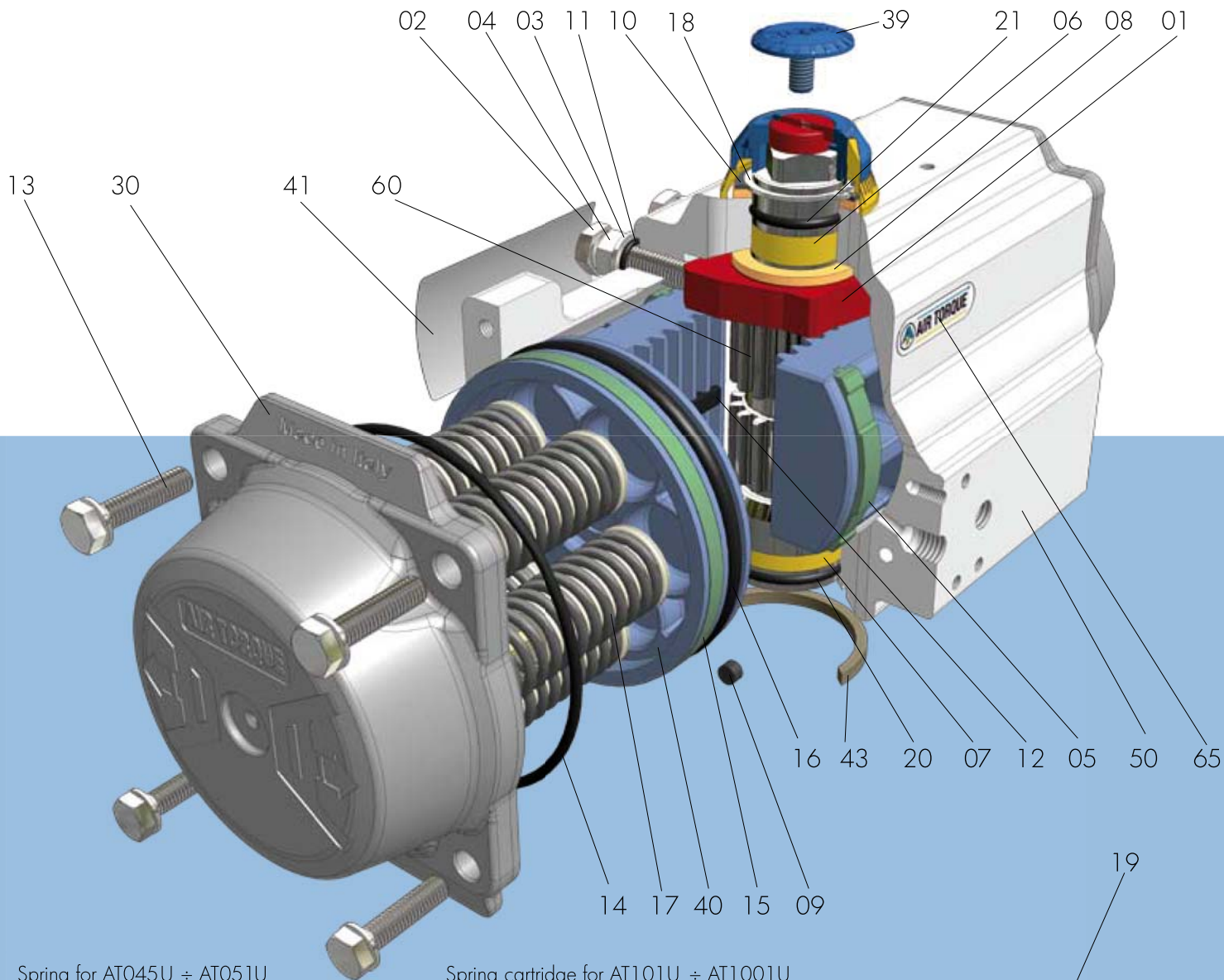

Spring for AT045U ÷ AT051U

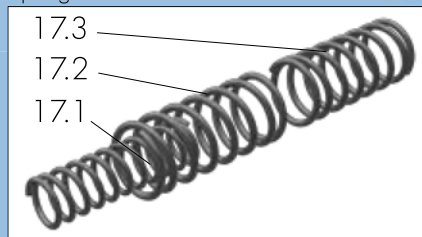

Spring cartridge for AT101U ÷ AT1001U

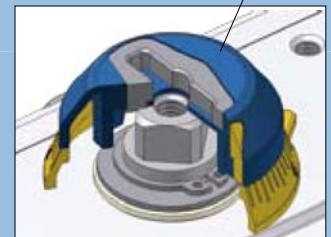

PART N°	Spare Parts	UNIT Q.TY / NOTE		PART DESCRIPTION	STANDARD MATERIAL
01		1	NA for AT045U	OCTI-CAM (Stop arrangement)	Stainless Steel (only for AT051U ÷ AT301U) Carbon Steel / Nodular Cast Iron, zinc coated
02		2	NA for AT045U	STOP CAP SCREW	Stainless Steel
03		2	NA for AT045U	WASHER	Stainless Steel
04		2	NA for AT045U	NUT (Stop screw)	Stainless Steel
05	○	2		BEARING (Piston back)	High-grade polymers
		4	for AT1001U		
06	○	1		BEARING (Pinion top)	High-grade polymers
07	○	1		BEARING (Pinion bottom)	High-grade polymers
08	○	2	1 Pc. for AT045U	THRUST BEARING (Pinion)	High-grade polymers
09	○ □	2		PLUG	M-NBR / Silicone
09.1	○ □	2	for AT801U ÷ AT1001U	"O-RING" PLUG	M-NBR / Silicone
10		1		THRUST WASHER (Pinion)	Stainless Steel
11	○ □	2	NA for AT045U	"O" RING (Stop screw)	M-NBR
12		2	NA for AT045U	PISTON GUIDE	High-grade polymers

○ Parts included in Complete spare parts kit

□ Parts included in "O" ring spare parts kit

AT801U

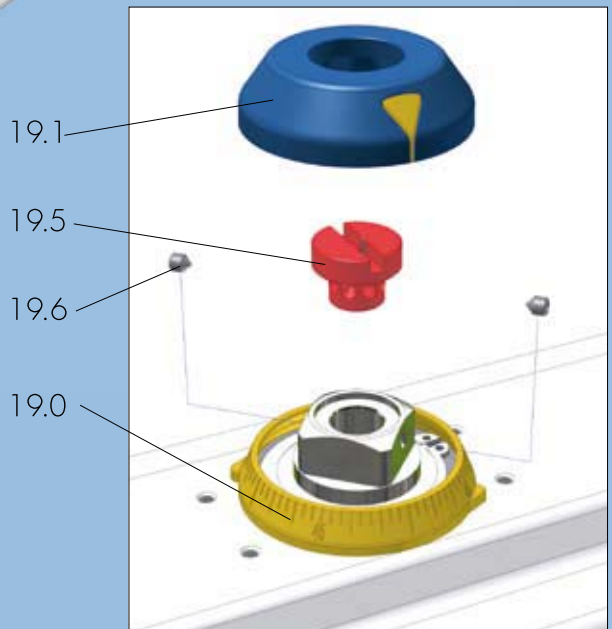
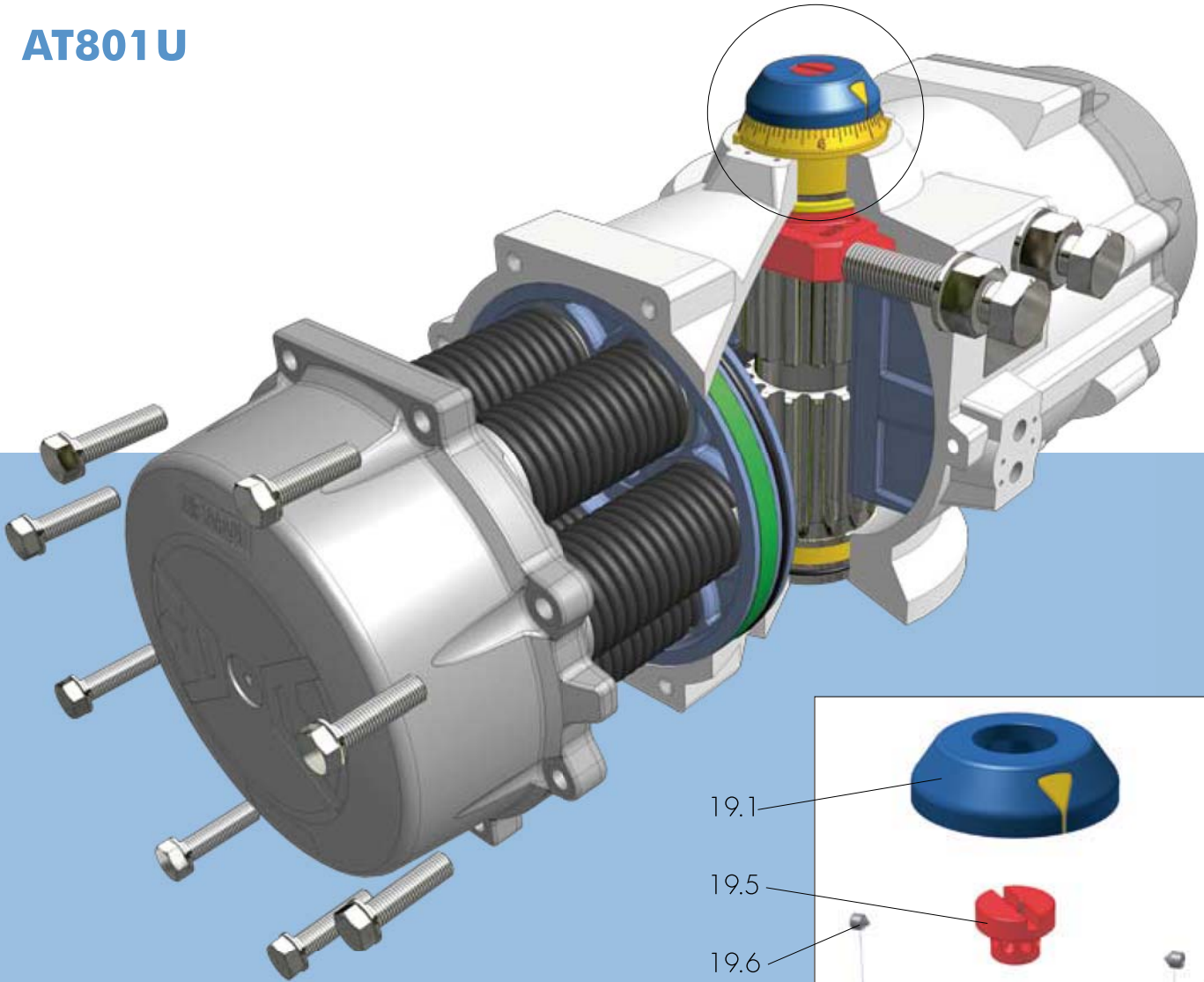

PART N°	Spare Parts	UNIT Q.TY / NOTE	PART DESCRIPTION	STANDARD MATERIAL
13		8 for AT045U ÷ AT651U	CAP SCREW (End cap)	Stainless Steel
		12 for AT701U ÷ AT751U		
		16 for AT801U ÷ AT1001U		
13.1		16 for AT1001U	WASHER (Cap Screw end cap)	Stainless Steel
14	<input type="checkbox"/>	2	"O" RING (End cap)	M-NBR
15	<input type="checkbox"/>	2	BEARING (Piston head)	High-grade polymers
16	<input type="checkbox"/>	2	"O" RING (Piston)	M-NBR
17		max. 12 for AT101U ÷ AT1001U	SPRING (Cartridge)	SiCr Spring alloy Steel coated
17.1			SPRING	
17.2		max. 2 for AT045U ÷ AT051U	SPRING	
17.3			SPRING	
18		1	SPRING CLIP (Pinion)	Spring Steel, ENP
19		1 for AT045U ÷ AT101U	POSITION INDICATOR	High-grade polymers / Stainless Steel
19.0		1	GRADUATED RING	High-grade polymers
19.1		1 NA for AT045U ÷ AT101U	POSITION INDICATOR	High-grade polymers
19.5		1 NA for AT045U ÷ AT101U	TOP ADAPTOR	Extruded Aluminium alloy, anodized
19.6		2 NA for AT045U ÷ AT101U	HEX. SOCKET SCREW (Top Adaptor)	Stainless Steel

Parts included in Complete spare parts kit

Parts included in "O" ring spare parts kit

AT1001U

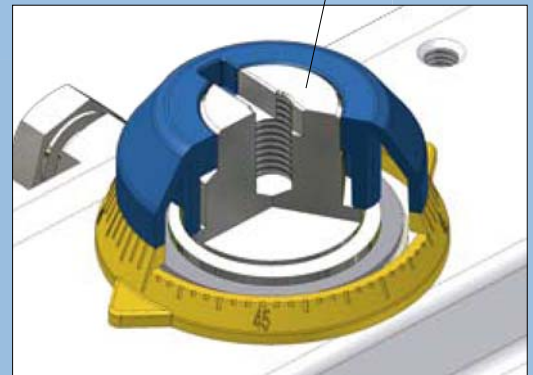
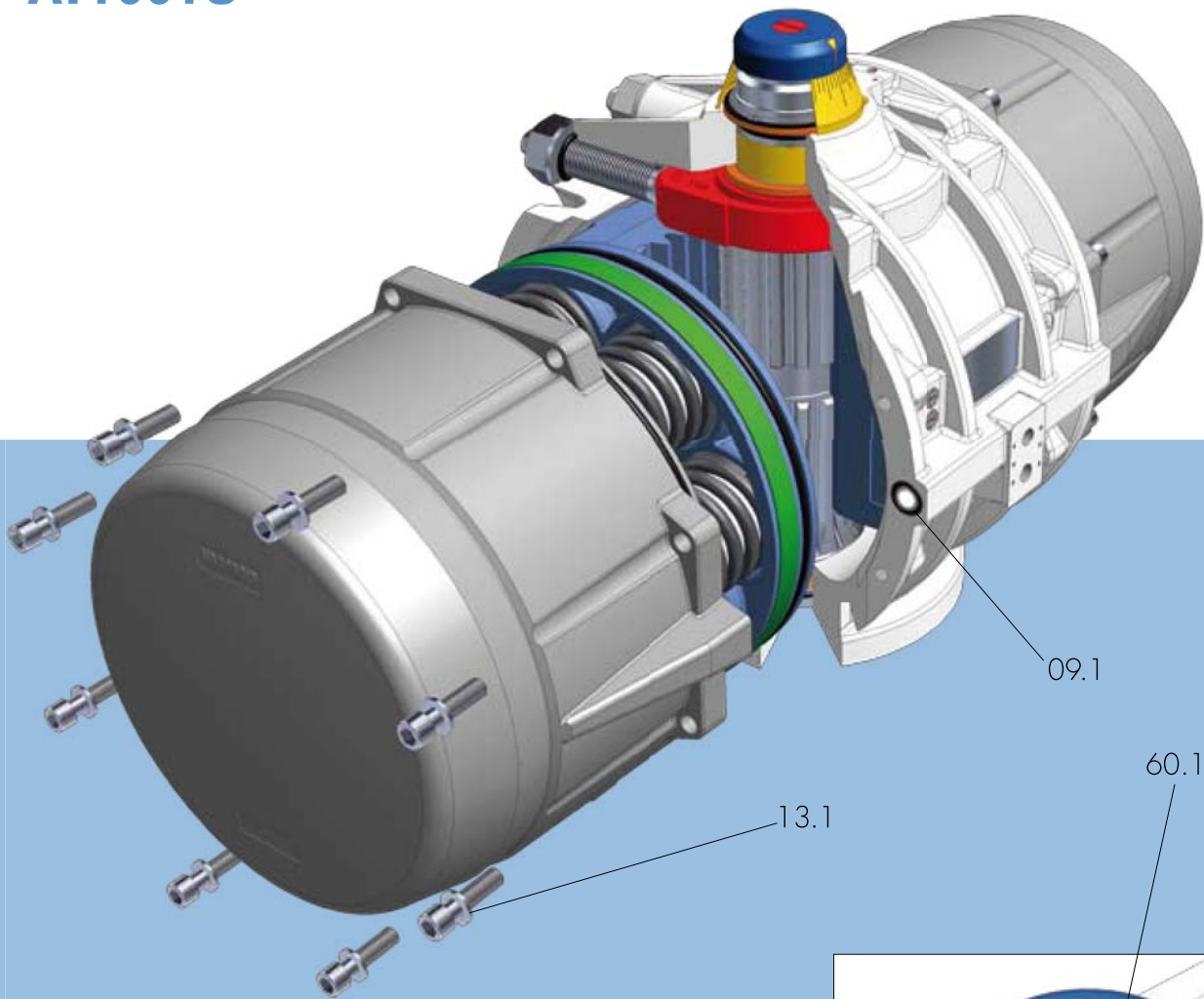

PART N°	Spare Parts	UNIT Q.TY / NOTE	PART DESCRIPTION	STANDARD MATERIAL
20	<input type="radio"/> <input type="checkbox"/>	1	"O" RING (Pinion bottom)	M-NBR
21	<input type="radio"/> <input type="checkbox"/>	1	"O" RING (Pinion top)	M-NBR
30		2	END CAP	Pressure Die Cast Aluminium alloy, anodized and coated Cast Aluminium alloy, anodized and coated (for AT1001U)
39		1	CAP SCREW (Indicator)	High-grade polymers
40		2	PISTON	Pressure Die Cast Aluminium alloy, anodized Cast Aluminium alloy, anodized (for AT1001U)
41		1	ACTUATOR IDENTIFICATION LABEL	Polyester-Silver
42		2	only for AT045U, AT751U and AT1001U END CAP LABEL	Polyester-Silver
43		1	SPIGOT (Only on request)	Extruded Aluminium alloy, anodized
50		1	BODY	Extruded Aluminium alloy, coated Cast Aluminium alloy, coated (for AT801U and AT1001U)
60		1	DRIVE SHAFT	Extruded Aluminium alloy, anodized (for AT045U and AT1001U) Steel, ENP
60.1		1	only for protection level "E" and "F" INTEGRAL DRIVE SHAFT	Stainless Steel, ENP
65		1	PLASTIC INSERT	High-grade polymers

Parts included in Complete spare parts kit

Parts included in "O" ring spare parts kit

DIMENSIONS AND TECHNICAL DATA

AIR CONNECTION VDI/VDE 3845

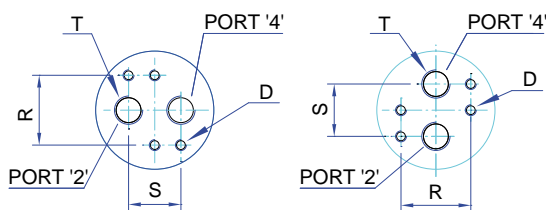

BOTTOM VIEW ISO 5211

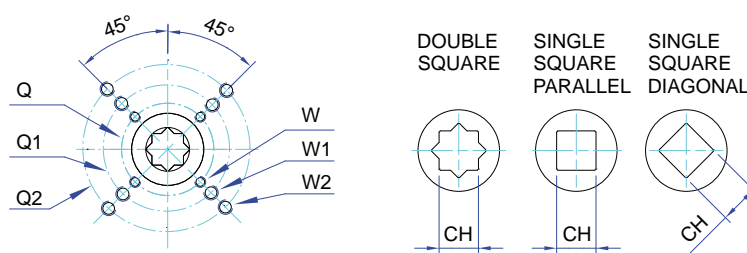

DIMENSIONS IN mm

ACTUATOR MODEL	AT045U D/S	AT051U D/S	AT101U D/S	AT201U D/S	AT251U D/S	AT301U D/S	AT351U D/S	AT401U D/S	AT451U D/S	AT501U D/S	AT551U D/S	AT601U D/S	AT651U D/S	AT701U D/S	AT751U D/S	AT801U D/S	AT1001U D/S	
A	118	135,5	153,5	203,5	241	259	304	333	394,5	422,5	474	528	605	710	812	855	950	
B	66	69	85	102	115	127	145	157	177	196	220,5	245	298,5	330	383	410	518	
C	62	71	84,5	93	106	118,5	136	146,5	166	181	200	221,5	262	330	371	418	528	
D	M5x8	M5x8	M5x8	M5x8	M5x8	M5x8	M5x8	M5x8	M5x8	M5x8	M5x8	M5x8	M6x10	M6x10	M6x10	M6x10	M6x10	
E	M5x8	M5x8	M5x8	M5x8	M5x8	M5x8	M5x8	M5x8	M5x8	M5x8	M5x8	M5x8	M5x8	M5x8	M5x8	M5x8	M6x10	
F	80	80	80	80	80	80	80	80	80	80	130	130	130	130	130	130	200	
G	30	30	30	30	30	30	30	30	30	30	30	30	30	30	30	30	50	
N	11	11	11	17	17	17	27	27	27	27	36	36	36	36	36	36	36	
P	15/20	20	20	20	20	20	30	30	30	30	50	50	50	50	50	50	80	
R	32	32	32	32	32	32	32	32	32	32	32	32	45	45	45	45	45	
S	24	24	24	24	24	24	24	24	24	24	24	24	40	40	40	40	40	
T ISO 228	1/8"	1/8"	1/8"	1/8"	1/8"	1/4"	1/4"	1/4"	1/4"	1/4"	1/4"	1/4"	3/8"	1/2"	1/2"	1/2"	1/2"	
Ø Z1	42	42	42	42	42	42	58	58	67,5	67,5	80	80	115	115	115	115	135	
ISO Flange	F04	F04	F05 + F07	F05 + F07	F05 + F07	F07 + F10	F07 + F10	F07 + F10	F10 + F12	F10 + F12	F14	F14	F16	F16	F16	F16 + F25	F16 + F25 + F30	
Q	42	42	50	50	50	70	70	70	102	102	140	140	165	165	165	165	165	
Q1	-	-	70	70	70	102	102	102	125	125	-	-	-	-	-	254	254	
Q2	-	-	-	-	-	-	-	-	-	-	-	-	-	-	-	-	298	
W	M5	M5	M6	M6	M6	M8	M8	M8	M10	M10	M16	M16	M20	M20	M20	M20	M20	
W1	-	-	M8	M8	M8	M10	M10	M10	M12	M12	-	-	-	-	-	M16	M16	
W2	-	-	-	-	-	-	-	-	-	-	-	-	-	-	-	-	M20	
OPTIONAL ISO Flange	F03	F03 + F05	F03 + F05	F05	F07	F05 + F07	F10	F10	F12	F12	F10 + F12	F10 + F12	F12	F12	F14	F25	F30	
CH x l min.	D	9 x 11	9 x 11	11 x 12	11 x 12	14 x 16	14 x 16	17 x 19	22 x 24	22 x 24	22 x 24	22 x 24	27 x 29	27 x 29	55 x 59	55 x 59	75 x 80	
	DS	11 x 12	14 x 16	14 x 16	14 x 16	17 x 19	22 x 24	27 x 29	27 x 29	27 x 29	36 x 39	36 x 39	46 x 49	46 x 49	-	-	-	
	D	-	-	17 x 19	17 x 19	22 x 24	-	-	-	-	-	-	-	-	-	-	-	
	DS	9 x 11	11 x 12	11 x 12	14 x 16	17 x 19	17 x 19	17 x 19	22 x 24	27 x 29	27 x 29	27 x 29	27 x 29	36 x 39	36 x 39	46 x 49	46 x 49	55 x 59
		11 x 12	-	14 x 16	17 x 16	-	22 x 24	22 x 24	27 x 29	-	-	36 x 39	36 x 39	46 x 49	46 x 49	55 x 59	55 x 59	75 x 80

TECHNICAL DATA (METRIC UNIT)

METRIC	MODEL TYPE	AT045U		AT051U		AT101U		AT201U		AT251U		AT301U		AT351U		AT401U		AT451U		AT501U		AT551U		AT601U		AT651U		AT701U		AT751U		AT801U		AT1001U	
		D	S	D	S	D	S	D	S	D	S	D	S	D	S	D	S	D	S	D	S	D	S	D	S	D	S	D	S	D	S	D	S		
Opening Time (Sec.)		0,15	0,2	0,2	0,25	0,25	0,3	0,3	0,4	0,4	0,5	0,5	0,7	0,7	0,9	0,9	1,2	1,2	1,5	1,5	1,8	2	2,4	2,7	3,5	3,5	4,1	4	4,5	5	6	6	7,5	8	10
Closing Time (Sec.)		0,2	0,25	0,25	0,3	0,3	0,35	0,35	0,5	0,5	0,6	0,6	0,9	0,8	1,1	1,1	1,4	1,4	1,8	1,7	2,1	2,2	2,8	3,2	4	4	4,6	4,5	5	6	7	7	8,5	9	11
Air Volume Opening (L)		0,06		0,09		0,16		0,31		0,51		0,71		1,19		1,54		2,41		3,14		4,26		5,94		10		14,5		20		25		49	
Air Volume Closing (L)		0,1		0,15		0,26		0,49		0,78		1,11		1,8		2,34		3,78		4,92		6,89		9,46		15,2		21,4		33		40		84	
Approximate Weight (Kg)		0,75	0,9	1,1	1,3	1,6	1,8	2,7	3	3,8	4,4	5,2	6	8,1	9,4	10	12,4	14,2	17,1	17,8	21,4	24,3	32,7	34,3	43,6	54,6	69	76,3	95,5	118	150	127	169	170	238

Note: (A) The above moving times of the actuator are obtained in the following test conditions:

For model AT045U ÷ AT501U: (1) Room Temperature, (2) Actuator Stroke 90°, (3) Solenoid Valve with Orifice Of 4 mm and a flow capacity Qn 400L/min., (4) Inside pipe diameter 8 mm, (5) Medium clean air, (6) Air supply pressure 5,5 bar (79,75 Psi), (7) Actuator without external resistance load.

For model AT551U ÷ AT1001U: (1) Room Temperature, (2) Actuator Stroke 90°, (3) Solenoid Valve with Orifice Of 11 mm and a flow capacity Qn 6000L/min., (4) Inside pipe diameter 11 mm, (5) Medium clean air, (6) Air supply pressure 5,5 bar (79,75 Psi), (7) Actuator without external resistance load.

Cautions: obviously on the field applications when one or more of the above parameter are different, the moving time will be different.

FRONT VIEW

SIDE VIEW

TOP DETAIL

AT045U

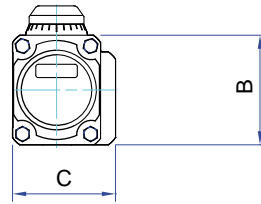
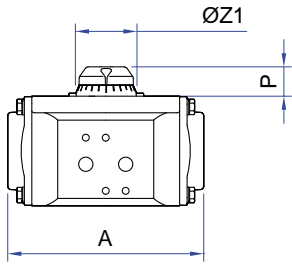

AT045U

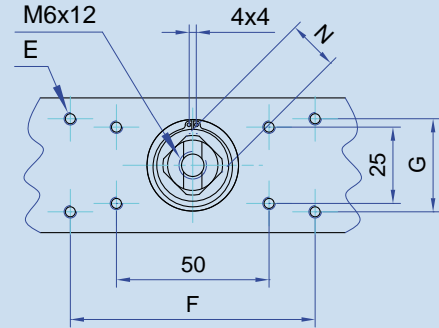

AT051 U ÷ AT651U

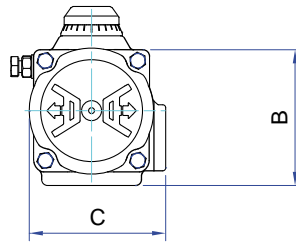
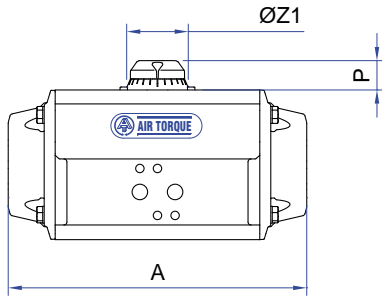

AT051U ÷ AT101U

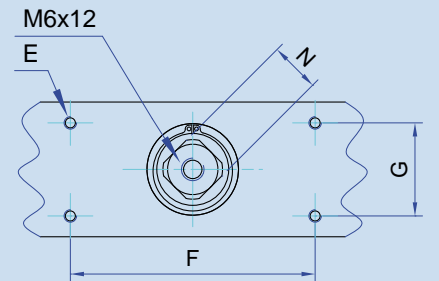

AT701 U ÷ AT751U

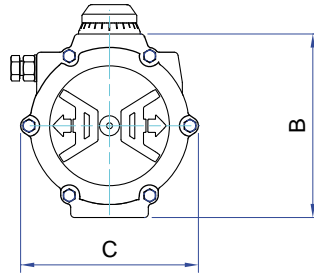
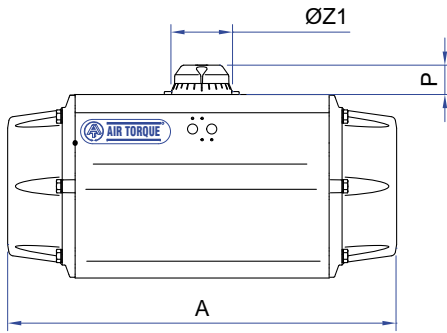

AT201U ÷ AT751U

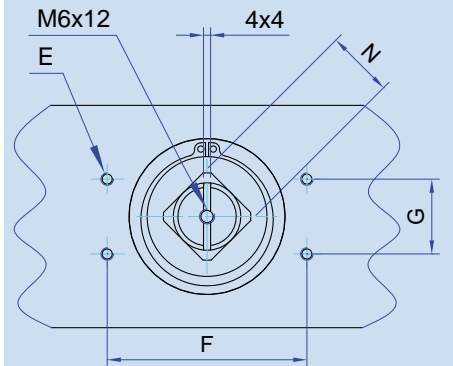

AT801U

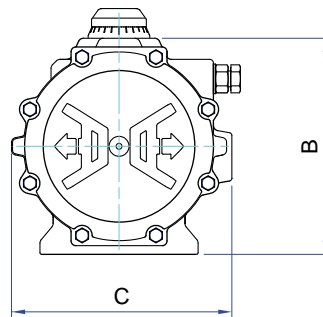
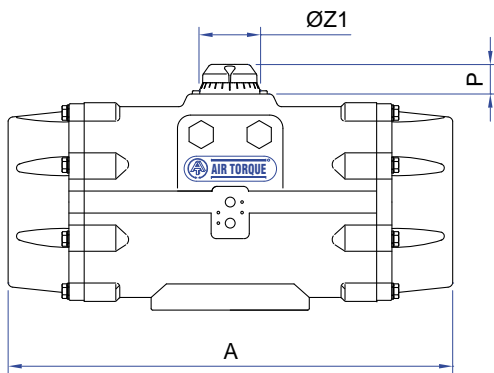

AT801U ÷ AT1001U

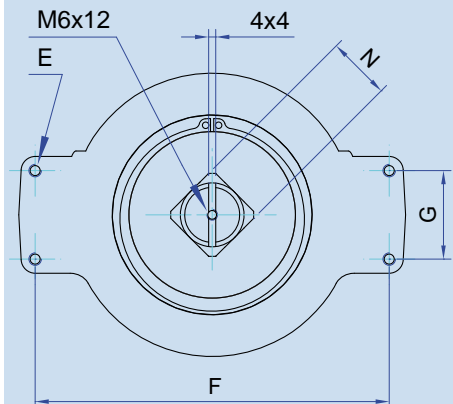

AT1001U

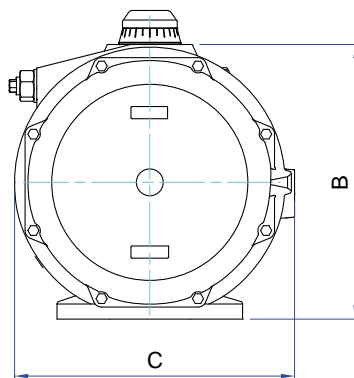
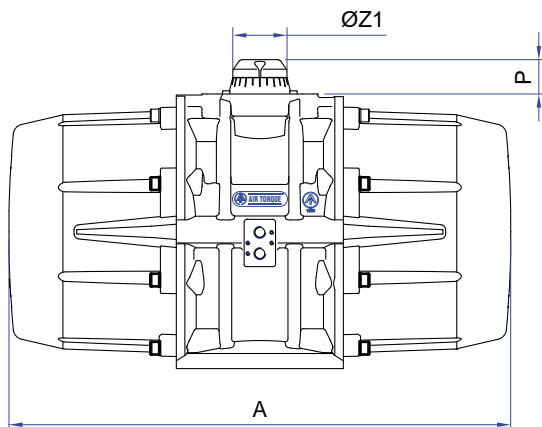

AIR CONNECTION VDI/VDE 3845

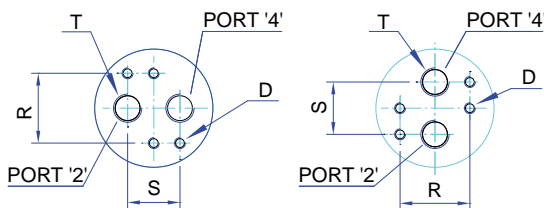

BOTTOM VIEW ISO 5211

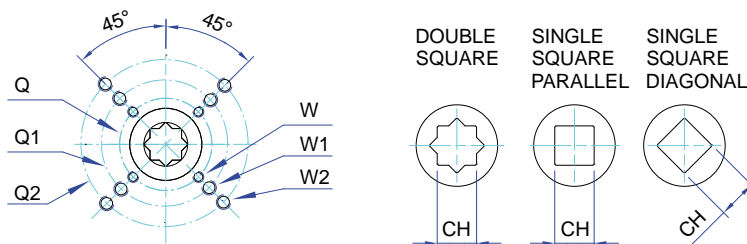

DIMENSIONS IN INCH

ACTUATOR MODEL	AT045U D/S	AT051U D/S	AT101U D/S	AT201U D/S	AT251U D/S	AT301U D/S	AT351U D/S	AT401U D/S	AT451U D/S	AT501U D/S	AT551U D/S	AT601U D/S	AT651U D/S	AT701U D/S	AT751U D/S	AT801U D/S	AT1001U D/S
A	4,65	5,33	6,04	8,01	9,49	10,20	11,97	13,11	15,53	16,63	18,66	20,79	23,82	27,95	31,97	33,66	37,40
B	2,60	2,72	3,35	4,02	4,53	5,00	5,71	6,18	6,97	7,72	8,68	9,65	11,75	12,99	15,08	16,14	20,39
C	2,44	2,80	3,33	3,66	4,17	4,67	5,35	5,77	6,54	7,13	7,87	8,72	10,31	12,99	14,61	16,46	20,79
D	M5x0,31	M5x0,31	M5x0,31	M5x0,31	M5x0,31	M5x0,31	M5x0,31	M5x0,31	M5x0,31	M5x0,31	M5x0,31	M5x0,31	M6x0,39	M6x0,39	M6x0,39	M6x0,39	M6x0,39
E	M5x0,31	M5x0,31	M5x0,31	M5x0,31	M5x0,31	M5x0,31	M5x0,31	M5x0,31	M5x0,31	M5x0,31	M5x0,31	M5x0,31	M5x0,31	M5x0,31	M5x0,31	M5x0,31	M6x0,39
F	3,15	3,15	3,15	3,15	3,15	3,15	3,15	3,15	3,15	3,15	5,12	5,12	5,12	5,12	5,12	5,12	7,87
G	1,18	1,18	1,18	1,18	1,18	1,18	1,18	1,18	1,18	1,18	1,18	1,18	1,18	1,18	1,18	1,18	1,97
N	0,43	0,43	0,43	0,67	0,67	0,67	1,06	1,06	1,06	1,06	1,42	1,42	1,42	1,42	1,42	1,42	1,42
P	0,59/0,79	0,79	0,79	0,79	0,79	0,79	0,79	1,18	1,18	1,18	1,97	1,97	1,97	1,97	1,97	1,97	3,15
R	1,26	1,26	1,26	1,26	1,26	1,26	1,26	1,26	1,26	1,26	1,26	1,26	1,77	1,77	1,77	1,77	1,77
S	0,94	0,94	0,94	0,94	0,94	0,94	0,94	0,94	0,94	0,94	0,94	0,94	1,57	1,57	1,57	1,57	1,57
T * ISO 228	1/8"	1/8"	1/8"	1/8"	1/8"	1/4"	1/4"	1/4"	1/4"	1/4"	1/4"	1/4"	3/8"	1/2"	1/2"	1/2"	1/2"
ØZ1	1,65	1,65	1,65	1,65	1,65	1,65	2,28	2,28	2,66	2,66	3,15	3,15	4,53	4,53	4,53	4,53	5,31
ISO Flange	F04	F04	F05 + F07	F05 + F07	F05 + F07	F07 + F10	F07 + F10	F07 + F10	F10 + F12	F10 + F12	F14	F14	F16	F16	F16	F16 + F25	F16 + F25 + F30
Q	1,65	1,65	1,97	1,97	1,97	2,76	2,76	2,76	4,02	4,02	5,51	5,51	6,50	6,50	6,50	6,50	6,50
Q1	-	-	2,76	2,76	2,76	4,02	4,02	4,02	4,92	4,92	-	-	-	-	-	10	10
Q2	-	-	-	-	-	-	-	-	-	-	-	-	-	-	-	-	11,73
W	M5	M5	M6	M6	M6	M8	M8	M8	M10	M10	M16	M16	M20	M20	M20	M20	M20
W1	-	-	M8	M8	M8	M10	M10	M10	M12	M12	-	-	-	-	-	M16	M16
W2	-	-	-	-	-	-	-	-	-	-	-	-	-	-	-	-	M20
OPTIONAL ISO Flange	F03	F03 + F05	F03 + F05	F05	F07	F05 + F07	F10	F10	F12	F12	F10 + F12	F10 + F12	F12	F12	F14	F25	F30
CH x l min.	D	0,35 x 0,43	0,35 x 0,43	0,43 x 0,47	0,43 x 0,47	0,55 x 0,63	0,55 x 0,63	0,67 x 0,75	0,87 x 0,94	0,87 x 0,94	0,87 x 0,94	0,87 x 0,94	1,06 x 1,14	1,06 x 1,14	1,217 x 2,32	2,17 x 2,32	2,95 x 3,15
	DS	0,43 x 0,47	0,43 x 0,47	0,55 x 0,63	0,55 x 0,63	0,67 x 0,75	0,67 x 0,75	0,87 x 0,94	1,06 x 1,14	1,06 x 1,14	1,06 x 1,14	1,06 x 1,14	1,42 x 1,54	1,42 x 1,54	1,81 x 1,93	1,81 x 1,93	2,17 x 2,32

* NPT (ANSI B1-20-1) threads available on request.

TECHNICAL DATA (IMPERIAL UNIT)

IMPERIAL MODEL TYPE	AT045U		AT051U		AT101U		AT201U		AT251U		AT301U		AT351U		AT401U		AT451U		AT501U		AT551U		AT601U		AT651U		AT701U		AT751U		AT801U		AT1001U	
	D	S	D	S	D	S	D	S	D	S	D	S	D	S	D	S	D	S	D	S	D	S	D	S	D	S	D	S	D	S	D	S		
Opening Time (Sec.)	0,15	0,2	0,2	0,25	0,25	0,3	0,3	0,4	0,4	0,5	0,5	0,6	0,7	0,8	0,9	1,1	1,2	1,4	1,5	1,7	2	2,2	2,7	3,2	3,5	4	4	4,5	5	6	6	7,5	8	10
Closing Time (Sec.)	0,2	0,25	0,25	0,3	0,3	0,35	0,35	0,5	0,5	0,6	0,7	0,8	0,9	1,1	1,2	1,4	1,5	1,8	1,8	2,1	2,4	2,8	3,5	4	4,1	4,6	4,5	5	6	7	7	8,5	9	11
Air Volume Opening (Cu. In.)	3,66		5,5		9,8		18,9		31,1		43,3		72,6		94		147,1		191,6		260		362,5		610,2		884,8		1220		1526		2990	
Air Volume Closing (Cu. In.)	6,1		9,2		15,9		29,9		47,6		67,7		109,8		142,8		230,7		300,2		420,5		577,3		927,6		1305		2014		2441		5126	
Approximate Weight (Lbs)	1,65	1,98	2,4	2,9	3,5	4,0	6,0	6,6	8,4	9,7	11,5	13,2	17,9	20,7	22,0	27,3	31,3	37,7	39,2	47,2	53,6	72,1	75,6	96,1	120	152	168	211	260	331	280	371	375	525

Note: (A) The above moving times of the actuator are obtained in the following test conditions:

For model AT045U ÷ AT501U: (1) Room Temperature, (2) Actuator Stroke 90°, (3) Solenoid Valve with Orifice Of 4 mm and a flow capacity Qn 400L/min., (4) Inside pipe diameter 8 mm, (5) Medium clean air, (6) Air supply pressure 5,5 bar (79,75 Psi), (7) Actuator without external resistance load.

For model AT551U ÷ AT1001U: (1) Room Temperature, (2) Actuator Stroke 90°, (3) Solenoid Valve with Orifice Of 11 mm and a flow capacity Qn 6000L/min., (4) Inside pipe diameter 11 mm, (5) Medium clean air, (6) Air supply pressure 5,5 bar (79,75 Psi), (7) Actuator without external resistance load.

Cautions: obviously on the field applications when one or more of the above parameter are different, the moving time will be different.

TORQUE OUTPUT (Nm)

SPRING RETURN TORQUE

Supply Pressure		2,5 bar		3 bar		3,5 bar		4 bar		4,2 bar		4,5 bar		5 bar		5,5 bar		6 bar		7 bar		8 bar		Spring stroke		
Model	Spring set	0°	90°	0°	90°	0°	90°	0°	90°	0°	90°	0°	90°	0°	90°	0°	90°	0°	90°	0°	90°	0°	90°	90°	0°	
		Start	End	Start	End	Start	End	Start	End	Start	End	Start	End	Start	End	Start	End	Start	End	Start	End	Start	End	Start	End	
AT045U	S 1-1	4,3	2,9																					3,1	1,7	
	S 1-2			4,7	2,4																				4,8	2,6
	S 2-2					4,9	2,0	6,1	3,2	6,6	3,7	7,3	4,4												6,4	3,5
	S 2-3											6,6	2,8			7,8	4,0	9,0	5,2	10,2	6,4				8,0	4,2
	S 3-3															8,2	3,6	9,4	4,8	11,8	7,2	14,1	9,5		9,6	5,0
AT051U	S 1	5,0	3,0	7	4,7	8	6,3	10,0	8	9,4	8,3	11,7	9,6	13,3	11,3										5,3	3,3
	S 2	4	1,9	6,0	3,6	7,7	5,3	9,3	6,9	9	7,4	11,0	8,6	12,7	10,2	14,3	11,9								6,4	4,0
	S 3			5,3	2,5	7,0	4,2	8,7	5,8	8,2	6,6	10,3	7,5	12,0	9,2	13,7	10,8	15,3	12,5						7,4	4,6
	S 4					6,3	3	8,0	5	7,6	5,8	9,7	6,4	11,3	8,1	13,0	9,8	14,7	11,4	18,0	14,7				8,5	5,3
	S 5							7,3	3,7	7,0	4,9	9,0	5,4	10,7	7,0	12,3	8,7	14,0	10,4	17,3	13,7	20,6	17,0		9,6	5,9
	S 6											8,4	4,3	10,0	6,0	11,7	7,6	13,3	9,3	16,7	12,6	20,0	16		10,6	6,6
	S 7													9,4	4,9	11	6,6	13	8,2	16,0	11,6	19,3	14,9		11,7	7,3
	S 8															10,4	6	12,0	7,2	15,3	10,5	18,7	13,8		12,8	7,9
AT101U	S 05	9,1	6,2	12	9,2	15	12,1	17,9	15	19,1	16,2	20,8	17,9	23,8	20,9										8,4	5,5
	S 06	8	4,5	10,9	7,5	13,9	10,4	16,8	13,3	18	14,5	19,7	16,3	22,7	19,2	25,6	22,1								10,1	6,7
	S 07			9,8	5,8	12,8	8,7	15,6	11,6	16,9	12,8	18,6	14,6	21,5	17,5	24,5	20,4	27,4	23,4						11,8	7,8
	S 08					11,6	7	14,6	10	15,7	11,1	17,5	12,9	20,4	15,8	23,4	18,7	26,3	21,7	32,2	27,5				13,5	8,9
	S 09							13,5	8,3	14,6	9,4	16,4	11,2	19,3	14,1	22,3	17,1	25,2	20	31,1	25,9	36,9	31,7		15,2	10
	S 10											15,3	9,5	18,2	12,4	21,1	15,4	24,1	18,3	29,9	24,2	35,8	30		16,9	11,1
	S 12													17,1	10,8	20	13,7	23	16,6	28,8	22,5	34,7	28,3		18,6	12,2
AT201U	S 05	18	11,8	23,8	17,6	29,7	23,4	35,5	29,2	37,8	31,6	41,3	35	47,1	40,9										17,3	11,1
	S 06	15,8	8,3	21,6	14,1	27,5	19,9	33,3	25,8	35,6	28,1	39,1	31,6	44,9	37,4	50,7	43,2								21	13,3
	S 07			19,4	10,7	25,2	16,5	31,1	22,3	33,4	24,6	36,9	28,1	42,7	33,9	48,5	39,8	54,3	45,6						24,2	15,5
	S 08					23	13	28,8	18,8	31,2	21,2	34,7	24,7	40,5	30,5	46,3	36,3	52,1	42,1	63,7	53,7				27,7	17,7
	S 09							26,6	15,4	29	17,7	32,5	21,2	38,3	27	44,1	32,8	49,9	38,6	61,5	50,3	73,2	61,9		31	19,9
	S 10											30,2	17,7	36,1	23,6	41,9	29,4	47,7	35,2	59,3	46,8	71	58,5		34,6	22,1
	S 11													33,8	20,1	39,7	25,9	45,5	31,7	57,1	43,4	68,7	55		38,1	24,3
	S 12															37,5	22,4	43,3	28,3	54,9	39,9	66,5	51,5		41,5	26,5
AT251U	S 05	27,4	16,9	36,6	26	45,7	35,2	54,9	44,3	58,5	48	64	53,5	73,2	62,6										28,9	18,3
	S 06	23,8	11,1	32,9	20,3	42,1	29,4	51,2	38,6	54,9	42,2	60,4	47,7	69,5	56,9	78,7	66								34,7	22
	S 07			29,2	14,5	38,4	23,6	47,5	32,8	51,2	36,4	56,7	41,9	65,8	51,1	75	60,2	84,2	69,4						40,4	25,7
	S 08					34,7	17,9	43,9	27	47,5	30,7	53	36,2	62,2	45,3	71,3	54,5	80,5	63,6	98,8	81,9				46,2	29,3
	S 09							40,2	21,2	43,9	24,9	49,4	30,4	58,5	39,5	67,7	49	76,8	57,8	95,1	76,1	113	94,5		52	33
	S 10											45,7	24,6	54,8	33,8	64	42,9	73,1	52,1	91,5	70,4	110	88,7		57,8	36,7
	S 11													51,2	28	60,3	37,1	69,5	46,3	87,8	64,6	106	82,9		63,5	40,3
S 12															56,7	31,4	65,8	40,5	84,1	58,8	102	77,1		69,3	44	
AT301U	S 05	41,1	27,1	54,4	40,4	67,7	53,7	81	67	86,3	72,3	94,3	80,3	108	93,6										39,4	25,3
	S 06	36,1	19,2	49,4	32,5	62,7	45,8	76	59,1	81,3	64,4	89,3	72,4	103	85,7	116	99								47,3	30,4
	S 07			44,3	24,6	57,6	37,9	70,9	51,2	76,2	56,5	84,2	64,5	97	77,8	111	91,1	124	104						55,1	35,5
	S 08					52,5	30	65,8	43,3	71,1	48,7	79,1	56,6	92,4	69,9	106	83,2	119,0	96,5	146	123				63	40,5
	S 09							60,8	35,5	66,1	40,8	74,0	48,8	87,3	62,1	101	75,3	113,9	88,6	141	115	167	142		70,9	45,6
	S 10											69	40,9	82,3	54,2	95,6	67,5	109	80,8	135	107	162	134		78,8	50,7
	S 11													77,2	46,3	90,5	59,6	104	72,9	130	99	157	126		86,7	55,7
S 12															85,4	51,7	99	65	125	92	152	118		94,5	60,8	
AT351U	S 05	66,5	41,9	87,9	63,4	109,4	84,9	131	106	140	115	152	128	174	149										65,5	41
	S 06	58,3	28,8	79,7	50,3	101,2	71,8	123	93,3	131	102	144	115	166	136	187	158								78,6	49,2
	S 07			71,5	37,2	93	58,7	115	80,2	123	88,8	136	102	158	123	179	145	200	166						91,7	57,4
	S 08					84,8	45,6	106	67,1	115	75,7	128	88,6	149	110	171	132	192	153	235	196				105	65,6
	S 09							98,1	54	107	62,6	120	75	141	97	163	118	184	140	227	183	270	226		118	73,8
	S 10											111	62,4	133	83,9	154	105	176	127	219	170	262	213		131	82
	S 12													125	70,8	146	92,3	168	114	211	157	254	200		144	90,2
AT401U	S 05	86	56,1	114	83,8	141	111	169	139	180	150	197	167	224	195										82,4	52,5
	S 06	75,5	39,6	103	67,3	131	95,0	159	123	170	134	186	150	214	178	242	206								98,9	63
	S 07			92,7	50,8	120	78,5	148	106	159	117	176	134	203	162	231	189	259	217						115	73,5
	S 08					110	62	138	89,7	149	101	165	117	193	145	221	173	248	201	304	256				132	84
	S 09							127	73,3	138	84,3															

TORQUE OUTPUT (Nm)



SPRING RETURN TORQUE

Supply Pressure		2,5 bar		3 bar		3,5 bar		4 bar		4,2 bar		4,5 bar		5 bar		5,5 bar		6 bar		7 bar		8 bar		Spring stroke			
Model	Spring set	0° 90°		0° 90°		0° 90°		0° 90°		0° 90°		0° 90°		0° 90°		0° 90°		0° 90°		0° 90°		0° 90°		90°	0°		
		Start	End	Start	End	Start	End	Start	End	Start	End	Start	End	Start	End	Start	End	Start	End	Start	End	Start	End				
AT601U	S 05	319	217	426	323	532	430	638	536	681	578	745	642	851	749									315	213		
	S 06	277	154	383	260	489	367	596	473	638	515	702	579	808	686	915	792							378	255		
	S 07			341	197	447	304	553	410	596	453	660	516	766	623	872	729	979	835					441	298		
	S 08					404	241			468	284	511	327	575	390	617	453	723	560	830	666	936	772	1149	985	504	340
	S 09													532	327	638	434	745	540	851	646	1064	859	1277	1072	630	425
	S 10															596	371	702	477	809	583	1021	796	1234	1009	693	468
	S 11																	660	414	766	520	979	733	1192	946	756	510
	S 12																										
AT651U	S 05	533	372	712	551	890	730	1069	908	1141	980	1248	1087	1426	1266									521	360		
	S 06	461	268	640	447	818	625	997	804	1068	876	1176	983	1354	1162	1533	1340							625	433		
	S 07			568	343	746	521	925	700	996	771	1104	879	1282	1057	1461	1236	1640	1415					730	505		
	S 08					674	417	853	596	924	667	1032	774	1210	953	1389	1132	1568	1310	1925	1668			834	577		
	S 09							781	491	852	563	959	670	1138	849	1317	1028	1495	1206	1853	1564	2210	1921	938	649		
	S 10											887	566	1066	745	1245	923	1423	1102	1781	1459	2138	1817	1042	721		
	S 11													994	640	1173	819	1351	998	1709	1355	2066	1713	1146	793		
	S 12															1101	715	1279	894	1637	1251	1994	1608	1251	865		
AT701U	S 05	751	496	1011	755	1270	1015	1529	1274	1633	1378	1789	1533	2048	1793									801	546		
	S 06	642	336	902	595	1161	854	1420	1114	1524	1217	1680	1373	1939	1632	2198	1892							961	655		
	S 07			792	435	1052	694	1311	954	1415	1057	1570	1213	1830	1472	2089	1732	2349	1991					1121	764		
	S 08					943	534	1202	793	1306	897	1461	1053	1721	1312	1980	1571	2239	1831	2758	2350			1281	873		
	S 09							1093	633	1197	737	1352	893	1612	1152	1871	1411	2130	1671	2649	2189	3168	2708	1442	982		
	S 10													1243	732	1503	992	1762	1251	2021	1510	2540	2029	3059	2548	1602	1091
	S 11															1393	832	1653	1091	1912	1350	2431	1869	2950	2388	1762	1200
	S 12																1544	931	1803	1190	2322	1709	2840	2228	1922	1309	
AT751U	S 05	1064	703	1423	1062	1782	1421	2141	1780	2284	1924	2500	2139	2859	2498									1092	731		
	S 06	918	485	1277	844	1636	1203	1995	1562	2138	1706	2354	1921	2713	2280	3072	2639							1310	877		
	S 07			1131	626	1489	985	1848	1344	1992	1487	2207	1703	2566	2062	2925	2421	3284	2780					1528	1023		
	S 08					1343	766	1702	1125	1846	1269	2061	1484	2420	1843	2779	2202	3138	2561	3856	3279			1746	1170		
	S 09							1556	907	1700	1051	1915	1266	2274	1625	2633	1984	2992	2343	3710	3061	4428	3779	1965	1316		
	S 10											1769	1048	2128	1407	2487	1766	2846	2125	3564	2843	4282	3560	2183	1462		
	S 11													1982	1188	2341	1547	2700	1906	3418	2624	4135	3342	2401	1608		
	S 12															2194	1329	2553	1688	3271	2406	3989	3124	2620	1754		
AT801U	S 05	1332	1014	1783	1465	2233	1915	2684	2365	2864	2546	3134	2816	3585	3266									1238	920		
	S 06	1149	767	1599	1217	2049	1667	2500	2118	2680	2298	2950	2568	3401	3019	3851	3469							1486	1104		
	S 07			1415	969	1865	1420	2316	1870	2496	2050	2766	2321	3217	2771	3667	3222	4118	3672					1733	1288		
	S 08					1682	1172	2132	1623	2312	1803	2582	2073	3033	2524	3483	2974	3934	3424	4835	4325			1981	1472		
	S 09							1948	1375	2128	1555	2398	1825	2849	2276	3299	2726	3750	3177	4651	4078	5551	4978	2229	1656		
	S 10											2215	1578	2665	2028	3115	2479	3566	2929	4467	3830	5386	4731	2476	1839		
	S 11													2481	1781	2931	2231	3382	2682	4283	3582	5184	4483	2724	2023		
	S 12															2748	1983	3198	2434	4099	3335	5000	4236	2971	2207		
AT1001U	S 05	2474	1695	3308	2529	4142	3362	4976	4196	5310	4530	5810	5030	6644	5864									2475	1695		
	S 06	2135	1200	2969	2034	3803	2867	4637	3701	4971	4035	5471	4535	6305	5369	7139	6203							2970	2034		
	S 07			2630	1539	3464	2373	4298	3206	4632	3540	5132	4040	5966	4874	6800	5708	7633	6542					3465	2373		
	S 08					3125	1878	3959	2711	4292	3045	4793	3545	5627	4379	6461	5213	7294	6047	8962	7715			3960	2712		
	S 09							3620	2217	3953	2550	4454	3050	5288	3884	6122	4718	6955	5552	8623	7220	10291	8887	4455	3051		
	S 10											4115	2555	4949	3389	5783	4223	6616	5057	8284	6725	9952	8393	4949	3390		
	S 11													4610	2894	5444	3728	6277	4562	7945	6230	9613	7898	5444	3729		
	S 12															5105	3233	5938	4067	7606	5735	9274	7403	5939	4068		
Spring set	The above value are the out-put torque that remain available to operate the valve when the part "2" is pressurized																						Out-put torque available when air supply fails				

DOUBLE ACTING TORQUE

Supply Pressure	2,5 bar	3 bar	3,5 bar	4 bar	4,2 bar	4,5 bar	5 bar	5,5 bar	6 bar	7 bar	8 bar
AT045U D	6,0	7,2	8,4	9,6	10,1	10,8	12,0	13,2	14,4	16,8	19,1
AT051U D	8,3	10,0	11,6	13,3	14,0	15,0	16,6	18,3	19,9	23,3	26,6
AT101U D	14,7	17,6	20,5	23,5	24,6	26,4	29,3	32,2	35,2	41,0	46,9
AT201U D	29,1	34,9	40,7	46,5	48,9	52,4	58,2	64,0	69,8	81,4	93,1
AT251U D	45,8	54,9	64,1	73,2	76,9	82,4	91,5	100,7	109,8	128,1	146,4
AT301U D	66,5	79,8	93,1	106	112	120	133	146	160	186	213
AT351U D	107	129	150	172	181	193	215	236	258	301	344
AT401U D	138	166	194	222	233	249	277	305	332	388	443
AT451U D	217	261	304	348	365	391	435	478	522	609	696
AT501U D	284	340	397	454	477	511	567	624	681	794	908
AT551U D	383	459	536	613							

TORQUE OUTPUT (Lb-In)



SPRING RETURN TORQUE

Supply Pressure		40 Psi		50 Psi		60 Psi		70 Psi		80 Psi		90 Psi		100 Psi		110 Psi		116 Psi		Spring stroke	
Model	Spring set	0°	90°	0°	90°	0°	90°	0°	90°	0°	90°	0°	90°	0°	90°	0°	90°	0°	90°	90°	0°
		Start	End	Start	End	Start	End	Start	End	Start	End	Start	End	Start	End	Start	End	Start	End	Start	End
AT045U	S 1-1	43.3	30.9	57.9	45.5	72.4	60.0	87.0	74.6	102	89.6	116	104	131	119					27.4	15.0
	S 1-2	35.3	15.8	49.9	30.4	64.4	44.9	79.0	59.5	94.0	74.5	108	88.5	123	103	138	119			42.5	23.0
	S 2-2			41.9	16.2	56.5	30.8	71.0	45.4	85.6	59.9	100	74.5	115	89.1	130	104	138	112	56.6	31.0
	S 2-3					50.3	16.6	68.4	31.2	79.4	45.8	94.0	60.3	109.0	74.9	124	90.2	132	98.2	70.8	37.2
	S 3-3							57.8	17.0	72.3	31.6	86.9	46.2	101.0	60.8	117	76.0	125	84.1	85.0	44.3
AT051U	S 1	51.9	34	72.2	54.4	92.5	74.7	113	94.9	133	115	153	136	174	156					47.1	29.2
	S 2	46.1	24.7	66.3	45.0	86.6	65	107	85.6	127	106	147	126	168	146	188	167			56.5	35.1
	S 3	40.2	15.2	60.5	35.5	81	55.8	101	76.1	121	96	142	117	162	137	182	157	194	169	65.9	40.9
	S 4			54.7	26.1	75	46.3	95.2	67	116	87	136	107	156	127	176	148	189	160	75	46.8
	S 5			48.8	16.7	69	37.0	89.4	57.3	110	78	130	98	150	118	171	138	183	151	84.8	52.6
	S 6					63.3	27.6	83.5	47.9	104	68	124	88.4	144	109	165	129	177	141	94.1	58.5
	S 7					57.4	18.1	77.7	38.4	98.0	58.7	118	79.0	139	99	159	120	171	132	104	64.3
	S 8							71.9	29.0	92.1	49.2	112.4	69.5	133	90	153	110	165	122	113	70.2
AT101U	S 05	94	68.5	130	104	166	140	201	176	237	212	273	247	309	283					74.7	49.1
	S 06	84.2	53.5	120	89.3	156	125	192	161	227	197	263	232	299	268	335	304			89.6	58.9
	S 07	74.4	38.6	110	74.4	146	110	182	146	218	182	253	218	289	253	325	289	346	311	105	68.8
	S 08			100	59.5	136	95.2	172	131	208	167	243	203	279	238	315	274	337	296	119	78.6
	S 09					126	80.3	162	116	198	152	234	188	269	223	305	259	327	281	134	88.4
	S 10							152	101	188	137	224	173	260	209	295	244	317	266	149	98.2
	S 11									178	122	214	158	250	194	286	229	307	251	164	108
	S 12													240	179	276	214	297	236	179	118
AT201U	S 05	186	131	257	202	328	273	399	344	470	415	541	486	612	557					153	97.8
	S 06	167	100	238	171	309	242	380	313	451	384	522	455	593	526	664	597			184	117
	S 07	147	70	218	141	289	212	360	283	431	354	502	425	573	496	644	567	687	609	214	137
	S 08			198	110	269	181	340	252	412	323	483	394	554	465	625	536	667	579	245	157
	S 09					250	150	321	221	392	292	463	363	534	434	605	505	648	548	276	176
	S 10							301	191	372	262	443	333	514	404	585	475	628	517	306	196
	S 11									353	231	424	302	495	373	566	444	608	487	337	215
	S 12													475	342	546	413	589	456	368	235
AT251U	S 05	285	191	396	303	508	415	620	526	731	638	843	750	955	862					256	162
	S 06	252	140	476	252	476	364	587	475	699	587	811	699	922	810	1034	922			307	195
	S 07	220	89	331	201	443	313	555	424	667	536	778	648	890	759	1002	871	1069	938	358	227
	S 08			299	150	411	261	522	373	634	485	746	597	858	708	969	820	1036	887	409	260
	S 09					378	210	490	322	602	434	713	545	825	657	937	769	1004	836	460	292
	S 10							457	271	569	383	681	494	793	606	904	718	971	785	511	325
	S 11									537	331	648	443	760	555	872	667	939	734	562	357
	S 12													728	504	839	616	906	683	613	389
AT301U	S 05	425	301	587	463	750	625	912	787	1074	950	1236	1112	1399	1274					349	224
	S 06	380	231	542	393	705	555	867	718	1029	880	1192	1042	1354	1205	1516	1367			418	269
	S 07	335	161	498	323	660	486	822	648	984	810	1147	973	1309	1135	1471	1297	1569	1395	488	314
	S 08			453	254	615	416	777	578	940	741	1102	903	1264	1065	1426	1227	1524	1325	558	359
	S 09					570	346	732	509	895	671	1057	833	1219	995	1382	1158	1479	1255	627	404
	S 10							688	439	850	601	1012	763	1174	926	1337	1088	1434	1185	697	449
	S 11									805	531	967	694	1130	856	1292	1018	1389	1116	767	493
	S 12													1085	786	1247	949	1344	1046	837	538
AT351U	S 05	687	470	949	732	1211	994	1474	1257	1736	1519	1998	1781	2260	2044					580	363
	S 06	614	354	876	616	1139	878	1401	1141	1663	1403	1926	1665	2188	1928	2450	2190			696	435
	S 07	541	238	804	500	1066	762	1328	1025	1591	1287	1853	1549	2115	1812	2378	2074	2535	2231	812	508
	S 08			731	384	993	646	1256	909	1518	1171	1780	1433	2043	1696	2305	1958	2463	2115	928	581
	S 09					921	530	1183	793	1446	1055	1708	1317	1970	1580	2233	1842	2390	1999	1044	653
	S 10							1111	677	1373	939	1635	1201	1898	1464	2160	1726	2317	1883	1160	726
	S 11									1300	823	1563	1085	1825	1348	2087	1610	2245	1767	1276	798
	S 12													1753	1232	2015	1494	2172	1652	1392	871
AT401U	S 05	888	623	1226	961	1564	1299	1902	1637	2240	1976	2578	2314	2916	2652					729	465
	S 06	795	477	1133	815	1471	1154	1809	1492	2147	1830	2485	2168	2823	2506	3161	2844			875	558
	S 07	702	331	1040	670	1378	1008	1716	1346	2054	1684	2392	2022	2730	2360	3069	2698	3271	2901	1021	651
	S 08			947	524	1285	862	1623	1200	1961	1538	2299	1876	2637	2214	2976	2552	3178	2755	1167	744
	S 09					1192	716	1530	1054	1868	1392	2206	1730	2544	2068	2883	2407	3085	2609	1313	837
	S 10							1437	908	1775	1246	2113	1584	2452	1923	2790	2261	2993	2464	1459	930
	S 11									1682	1100	2020	1439	2359	1777	2697	2115	2900	2318	1604	1023
	S 12													2266	1631	2604	1969	2807	2172	1750	1116
AT451U	S 05	1394	983	1925	1514	2456	2044	2987	2575	3517	3106	4048	3637	4579	4167					1140	729
	S 06	1248	755	1779	1285	2310	1816	2841	2347	3372	2878	3902	3409	4433	3939	4964	4470</				

TORQUE OUTPUT (Lb-In)



SPRING RETURN TORQUE

Supply Pressure		40 Psi		50 Psi		60 Psi		70 Psi		80 Psi		90 Psi		100 Psi		110 Psi		116 Psi		Spring stroke		
Model	Spring set	0°	90°	0°	90°	0°	90°	0°	90°	0°	90°	0°	90°	0°	90°	0°	90°	0°	90°	90°	0°	
		Start	End	Start	End	Start	End	Start	End	Start	End	Start	End	Start	End	Start	End	Start	End	Start	End	
AT601U	S 05	3312	2406	4610	3704	5908	5003	7207	6301	8505	7599	9803	8898	11102	10196					2787	1882	
	S 06	2935	1849	4234	3147	5532	4445	6830	5744	8129	7042	9427	8340	10725	9639	12024	10937			3345	2258	
	S 07	2559	1291	3857	2589	5156	3888	6454	5186	7752	6485	9051	7783	10349	9081	11648	10380	12427	11159	3902	2634	
	S 08			3481	2032	4779	3330	6078	4629	7376	5927	8674	7225	9973	8524	11271	9822	12050	10601	4460	3011	
	S 09					4403	2773	5701	4071	7000	5370	8298	6668	9596	7966	10895	9265	11674	10044	5017	3387	
	S 10							5325	3514	6623	4812	7922	6110	9220	7409	10518	8707	11297	9486	5575	3763	
	S 11									6247	4255	7545	5553	8844	6851	10142	8150	10921	8929	6132	4140	
	S 12													8467	6294	9766	7592	10545	8371	6690	4516	
AT651U	S 05	5535	4113	7716	6294	9898	8475	12079	10657	14260	12838	16441	15019	18623	17200					4612	3190	
	S 06	4897	3190	7078	5372	9260	7553	11441	9734	13622	11915	15803	14097	17985	16278	20166	18459			5534	3828	
	S 07	4259	2268	6440	4449	8622	6631	10803	8812	12984	10993	15165	13174	17347	15356	19528	17537	20837	18845	6457	4466	
	S 08			5802	3527	7984	5708	10165	7889	12346	10071	14527	12252	16709	14433	18890	16614	20199	17923	7379	5104	
	S 09					7346	4786	9527	6967	11708	9148	13889	11329	16071	13511	18252	15692	19561	17001	8302	5742	
	S 10							8889	6045	11070	8226	13251	10407	15433	12588	17614	14770	18923	16078	9224	6380	
	S 11									10432	7303	12613	9485	14795	11666	16976	13847	18285	15156	10147	7018	
	S 12													14157	10743					11069	7656	
AT701U	S 05	7836	5576	11002	8742	14168	11907	17333	15073	20499	18239	23665	21405	26831	24571					7088	4828	
	S 06	6870	4158	10036	7324	13202	10490	16368	13656	19534	16822	22700	19987	25865	23153	29031	26319			8505	5793	
	S 07	5905	2741	9071	5906	12236	9072	15402	12238	18568	15404	21734	18570	24900	21736	28066	24902	29965	26801	9923	6759	
	S 08			8105	4489	11271	7655	14437	10821	17603	13986	20769	17152	23934	20318	27100	23484	29000	25384	11340	7724	
	S 09					10305	6237	13471	9403	16637	12569	19803	15735	22969	18901	26135	22067	28034	23966	12758	8690	
	S 10							12506	7986	15672	11151	18837	14317	22003	17483	25169	20649	27069	22549	14176	9655	
	S 11									14706	9734	17872	12900	21038	16066	24204	19231	26103	21131	15593	10621	
	S 12													20072	14648	23238	17814	25138	19713	17011	11586	
AT751U	S 05	11059	7868	15441	12250	19823	16632	24205	21014	28587	25395	32969	29777	37351	34159					9660	6469	
	S 06	9765	5936	14147	10318	18529	14700	22911	19081	27293	23463	31675	27845	36057	32227	40439	36610			11592	7763	
	S 07	8471	4004	12853	8386	17235	12767	21617	17149	25999	21531	30381	25913	34763	30295	39146	34678	41774	37306	13524	9056	
	S 08			11560	6454	15942	10835	20323	15217	24705	19599	29087	23981	33469	28363	37852	32746	40480	35374	15456	10350	
	S 09					14648	8903	19030	13285	23412	17667	27794	22049	32176	26431	36558	30814	39187	33442	17388	11644	
	S 10							17736	11353	22118	15735	26500	20117	30882	24499	35264	28882	37893	31510	19320	12938	
	S 11									20824	13803	25206	18185	29588	22567	33971	26950	36599	29578	21252	14231	
	S 12													28294	20635	32677	25018	35305	27646	23184	15525	
AT801U	S 05	13855	11037	19353	16536	24852	22034	30350	27533	35849	33031	41347	38530	46846	44028					10957	8140	
	S 06	12227	8846	17725	14344	23224	19843	28722	25341	34221	30840	39719	36338	45218	41837	50717	47335			13149	9767	
	S 07	10599	6654	16097	12153	21596	17651	27094	23150	32593	28648	38091	34147	43590	39645	49089	45144	52388	48443	15340	11395	
	S 08			14469	9961	19968	15460	25466	20958	30965	26457	36464	31955	41962	37454	47461	42953	50760	46252	17531	13023	
	S 09					18340	13268	23839	18767	29337	24265	34836	29764	40334	35263	45833	40761	49132	44060	19723	14651	
	S 10							22211	16576	27709	22074	33208	27573	38706	33071	44205	38570	47504	41869	21914	16279	
	S 11									26081	19883	31580	25381	37078	30880	42577	36378	45876	39677	24106	17907	
	S 12													35450	28688	40949	34187	44248	37486	26297	19535	
AT1001U	S 05	25715	18812	35894	28991	46073	39170	56252	49349	66431	59528	76610	69707	86790	79887					21904	15001	
	S 06	22715	14432	32894	24611	43073	34790	53252	44969	63431	55148	73610	65327	83789	75506	93968	85658			26285	18001	
	S 07	19715	10051	29894	20230	40073	30409	50252	40588	60431	50767	70610	60946	80789	71125	90968	81304	97076	87411	30665	21001	
	S 08			26894	15849	37073	26028	47252	36207	57431	46386	67610	56565	77789	66744	87968	76923	94076	83031	35046	24001	
	S 09					34073	21647	44252	31826	54431	42005	64610	52184	74789	62364	84968	72543	91075	78650	39427	27001	
	S 10							41252	27455	51431	37634	61610	47813	71789	57992	81968	68171	88075	74278	43799	30002	
	S 11									48431	33253	58610	43432	68789	53611	78968	63790	85075	69897	48179	33002	
	S 12													55609	39051	65788	49230	75967	59409	82075	65517	52600
Spring set		The above value are the out-put torque that remain available to operate the valve when the part "2" is pressurized																			Out-put torque available when air supply fails	

DOUBLE ACTING TORQUE

Supply Pressure	40 Psi	50 Psi	60 Psi	70 Psi	80 Psi	90 Psi	100 Psi	110 Psi	116 Psi
AT045U D	58.3	72.9	87.4	102	117	131	146	161	169
AT051U D	81.1	101	122	142	162	183	203	223	235
AT101U D	143	179	215	251	286	322	358	394	415
AT201U D	284	355	426	497	568	639	710	781	824
AT251U D	447	559	670	782	894	1005	1117	1229	1296
AT301U D	649	811	974	1136	1298	1461	1623	1785	1883
AT351U D	1049	1312	1574	1836	2099	2361	2623	2886	3043
AT401U D	1352	1691	2029	2367	2705	3043	3381	3719	3922
AT451U D	2123	2654	3185	3716	4246	4777	5308	5839	6157
AT501U D	2770	3462	4155	4847	5540	6232	6925	7617	8032
AT551U D	3739	4674	5609	6544	7479	8413	9348	10283	10844
AT601U D	5193	6492	7790	9088	10387	11685	12984	14282	15061
AT651U D	8725	10906	13087	15269	17450	19631	21812	23994	25302
AT701U D	12663	15829	18995	22161	25327	28493	31659	34825	36724
AT751U D	17528	21910	26292	30674	35056	39438	43820	48202	50831
AT801U D	21994	27493	32991	38490	43988	49487	54985	60484	63783
AT1001U D	40716	50895	61074	71253	81432	91611	101790	111969	**

** AT1001U D operated with 8 bar (116 Psi) supply pressure requires SPECIAL construction. Contact AIR TORQUE factory.

SPRING SET CONFIGURATION

AT045U configuration

Spring Set	Side B	Side A
	AT045U Spring type	AT045U Spring type
S1-1	1 (green)	1 (green)
S1-2	1 (green)	2 (red)
S2-2	2 (red)	2 (red)
S2-3	2 (red)	3 (black)
S3-3	3 (black)	3 (black)

AT051U configuration

Spring Set	Side B		Side A	
	AT051U Internal Spring type	AT051U External Spring type	AT051U Internal Spring type	AT051U External Spring type
S1	1 (green)	-----	-----	2 (black)
S2	-----	2 (black)	-----	2 (black)
S3	-----	2 (black)	-----	3 (red)
S4	-----	3 (red)	-----	3 (red)
S5	-----	3 (red)	1 (green)	2 (black)
S6	1 (green)	2 (black)	1 (green)	2 (black)
S7	1 (green)	2 (black)	1 (green)	3 (red)
S8	1 (green)	3 (red)	1 (green)	3 (red)

AT101U to AT1001U configuration

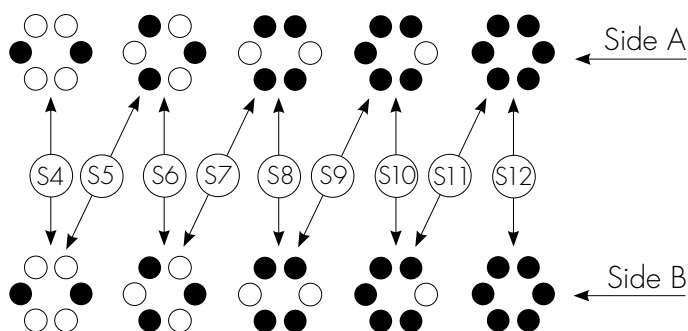

TYPICAL TORQUE CURVES FOR RACK PINION ACTUATORS

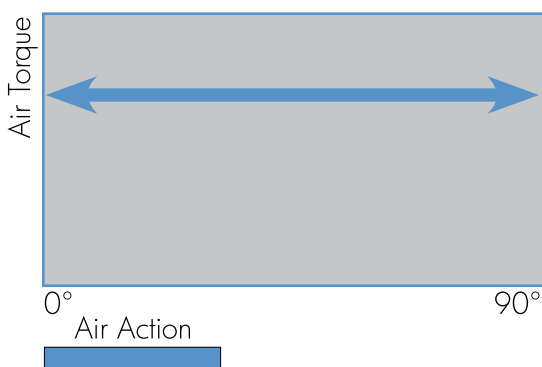

Torque output double acting

The double acting actuator has constant torque over the whole stroke, so that all that needs to be known for sizing is the maximum valve torque, which is multiplied by a safety factor (usually at least 25%-30% depending on the valve and service). The value thus obtained is then compared with figures in the minimum air pressure column in the actuator torque tables. After having found the same or nearest value (in excess), the suitable actuator model can be read from the column to the left.

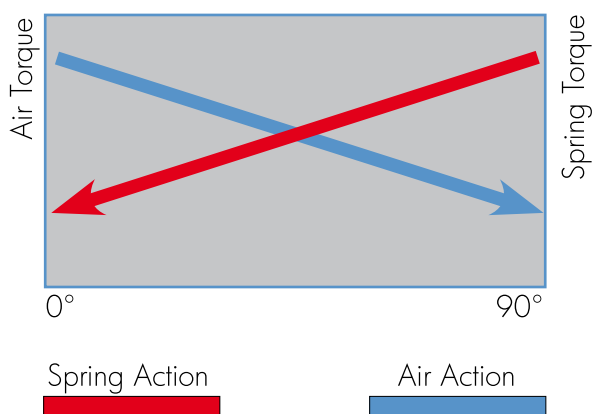

Torque output spring return

The spring return actuator has four different torque values: the air torques at 0° and 90° when it is pressurized, and the spring torques at 90° and 0° when the pressure is discharged. For a correct sizing, the torque curves of the actuator in both strokes have to be higher than the valve torque curves. Also for the spring return actuator sizing, the valve torques have to be multiplied by a safety factor (usually at least 25%-30% depending on the valve and service). The 4th Generation Line Upgrade Series are designed to give a balanced torque when the number of springs per side is equal to the air pressure supply in bar (for example 4 bar, 4 springs per side).

ACTUATOR INTERFACE FOR AUTOMATION

VDI/VDE3845 for ancillary attachment



VDI/VDE3845
for actuator pneu-
matic controls

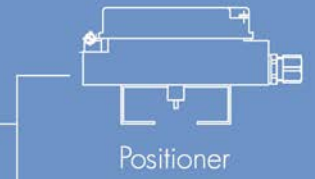

Positioner

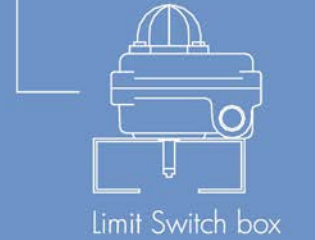

Limit Switch box

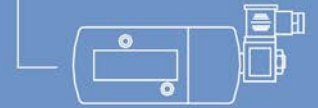

Namur Solenoid valve

ISO5211/DIN3337
for valve assembling



Spigot (on request)



Declutchable gear box



Mounting kits



Plug valve



Ball valve



Butterfly valve

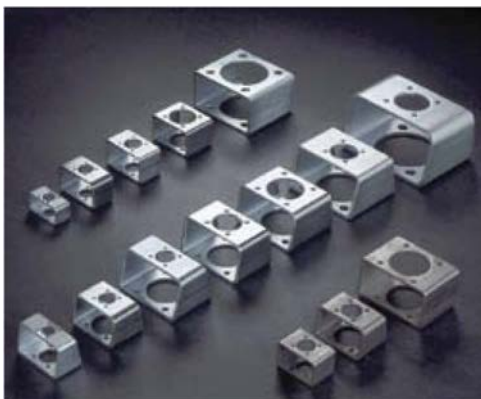

COUPLING AND BRACKETS

Air Torque has a large stock of couplings and brackets. All the accessories for valve automation available on request.

STANDARD PROTECTION LEVELS



PARTS	COATING
Body (AT045U to AT751U)	ALODUR anodized
Body (AT801U and AT1001U)	Anodized plus epoxy primer, plus polyurethane coating (RAL9007 - grey)
End-caps (AT045U to AT801U)	Anodized plus polyester coating (RAL9007 - grey - or RAL5015 blue)
End-caps (AT1001U)	Anodized plus polyester coating (RAL9007 - grey)
Carbon steel drive shaft (AT051U to AT801U)	ENP
Aluminum alloy drive shaft (AT045U and AT1001U)	ALODUR anodized

PROTECTION LEVEL A



PARTS	COATING
Body	ALODUR anodized plus PTFE coating (light grey)
End-caps	Anodized plus PTFE coating (light grey)
Carbon steel drive shaft (AT051U to AT801U)	ENP
Aluminum alloy drive shaft (AT045U and AT1001U)	ALODUR anodized

PROTECTION LEVEL D



PARTS	COATING
Body	ALODUR anodized plus epoxy coating (RAL7046 - grey)
End-caps	Anodized plus epoxy coating (RAL7046 - grey)
Stainless steel drive shaft	ENP
Stainless steel 316 fasteners	NA

PROTECTION LEVEL F



See technical data-sheet for protection details

STANDARD PROTECTION LEVELS



PARTS	COATING
Body	ALODUR anodized plus PTFE coating (light grey)
End-caps	Anodized plus polyester coating (RAL9007 - grey - or RAL5015 blue)
End-caps (AT1001U)	Anodized plus polyester coating (RAL9007 - grey)
Carbon steel drive shaft (AT051U to AT801U)	ENP
Aluminum alloy drive shaft (AT045U and AT1001U)	ALODUR anodized

PROTECTION LEVEL B



PARTS	COATING
Body	ALODUR anodized plus PTFE coating (light grey)
End-caps	Anodized plus PTFE coating (light grey)
Stainless steel drive shaft	ENP

PROTECTION LEVEL E



PARTS	COATING
Body (AT045U to AT751U)	ALODUR anodized
Body (AT801U and AT1001U)	Anodized
End-caps	Anodized
Carbon steel drive shaft (AT051U to AT801U)	ENP
Aluminum alloy drive shaft (AT045U and AT1001U)	ALODUR anodized

PROTECTION LEVEL P



AVAILABLE OPTIONS AND ORDERING CODES

0	Blank: octi-cam assembled for standard travel stop adjustment K: octi-cam assembled for lock-out capability (stroke adjustment limited at +/- 5°).	7	XXD (square dimensions): single square dimension and diagonal assembling XXL: single square dimension and parallel assembling XXDS: dimension and double square S x d (a): flat head dimensions W x d: double keys dimensions
00	Blank: for standard actuator R50: 50% travel stop limitation (45° up to 90°) R100: 100% travel stop limitation (0° up to 90°) FA: fast acting FM: fail mid 180° rotation 3P: 3 position (only for spring return) 3PD: 3 position (both for spring return and double acting) HC: hydraulic damper TS: top smart connection	8	Blank: actuator with standard seals suitable for -40°C (-40°F) to 80°C (+176°F) HT: actuator construction suitable for -15°C (+5°F) to 150°C (+302°F) LLT: actuator construction suitable for -55°C (-67°F) to 80°C (+176°F)
1	Actuator model, series and rotation AT045U to AT1001U: 90° (standard) AT052U up to AT752U: 120° AT053U to AT753U: 135° AT058U to AT758U: 180°	9	Blank: standard assembly type ST, clockwise to close (spring to close) and close indication at air failure condition (or with pressurized port 4 for double acting) for in line mounting. STR: clockwise to close (spring to close) and close indication at air failure condition (or with pressurized port 4 for double acting) for across line mounting. LF: counterclockwise to close (spring to open) and open indication at air failure condition (or with pressurized port 4 for double acting) for across line mounting. LFR: counterclockwise to close (spring to open) and open indication at air failure condition (or with pressurized port 4 for double acting) for in line mounting.
2	S: spring return D: double acting		
3	Only for spring return: number of springs, spring configuration set		
4	A, B, D, E, F, P: Protection level		
5	ISO Flange		
6	Blank: no spigot Y: with spigot	10	Further requested options

(a) head flat orientation to be specified

Examples of model designation

0	00	1	2	3	4	5	6	7	8	9	10
-	-	AT201U	S	12	B	F05-F07	Y	14D	HT	-	-

AT201, Upgrade Series, spring return with 12 springs, protection level B, ISO flange F05-F07, with spigot, 14 mm diagonal single square and high temperature construction.

0	00	1	2	3	4	5	6	7	8	9	10
K	-	AT351U	D	-	A	F07-F10	-	17DS	-	LFR	-

AT351, Upgrade series, with lock-out capability, double acting, protection level A, ISO flange F07-F10, 17 mm double square and counterclockwise to close (spring to open) and open indication at air failure condition (or with pressurized port 4 for double acting) for in line mounting.