

GATE VALVE PN16 (F4) series 115



GATE VALVES



APPLICATION

Flanged gate valve for drinking water and neutral liquids up to 70°C

DESIGN FEATURES

Non rising stainless steel stem	Guided wedge to ensure correct sealing
Full bore	100% watertight
Low closing torque	No zones of retention
Clockwise closing	Replaceable wedge nut
Maintenance free	

TECHNICAL CHARACTERISTICS

Design in accordance to EN1074 and EN1171
Face to face dimensions according to EN 558-1 series 14 and DIN3202 (F4)
Flange end connections according to EN1092-2: PN10&PN16
Maximum working pressure: PN16 / 16 bar
Working temperature: 0°C - +70°C
Fully vulcanized wedge in EPDM according to EN681
Stainless steel bolts
Color RAL5015
Powder epoxy coating at least 250 µm thickness

OPERATING



DN	Flange drilling	L	H	H1	D	D1	D2	b	n-Ød	SQ	KG	BLUCAST ref. no.
40	PN10/16	140	220	295	150	110	84	16	4-Ø19	14	9	115040
50	PN10/16	150	230	312,5	165	125	99	16	4-Ø19	14	10,6	115050
60/65	PN10/16	170	265	357,5	185	145	118	16	4-Ø19	17	11	115065
80	PN10/16	180	290	390	200	160	132	16	8-Ø19	17	12,6	115080
80	PN10/16	180	290	390	200	160	132	16	4-Ø19	17	12,6	115H080
100	PN10/16	190	335	445	220	180	156	16	8-Ø19	19	18	115100
125	PN10/16	200	380	505	250	210	184	16	8-Ø19	19	26,9	115125
150	PN10/16	210	415	557,5	285	240	211	16	8-Ø23	19	30,2	115150
200	PN10	230	510	680	340	295	266	17	8-Ø23	24	53	115200
200	PN16	230	510	680	340	295	266	17	12-Ø23	24	53	115P200
250	PN10	250	600	800	400	350	319	19	12-Ø23	27	73,5	115250
250	PN16	250	600	800	400	355	319	19	12-Ø28	27	73,5	115P250
300	PN10	270	690	917,5	455	400	370	20,5	12-Ø23	27	107,4	115300
300	PN16	270	690	917,5	455	410	370	20,5	12-Ø28	27	107,4	115P300
350	PN10	290	790	1042,5	505	460	429	22,5	16-Ø23	27	158,4	115350
350	PN10/16	290	790	1050	520	470	429	22,5	16-Ø28	27	158,4	115U350
400	PN10	310	855	1137,5	565	515	480	24	16-Ø28	27	201	115400
400	PN10/16	310	855	1145	580	525	480	24	16-Ø31	27	201	115U400
500	PN10	350	1072	1407	670	620	582	31,5	20-Ø28	32	344	115500
500	PN10/16	350	1072	1429,5	715	650	609	31,5	20-Ø34	32	344	115U500
600	PN10	390	1228	1618	780	725	682	36	20-Ø31	32	543	115600
600	PN10/16	390	1228	1648	840	770	720	36	20-Ø37	32	543	115U600

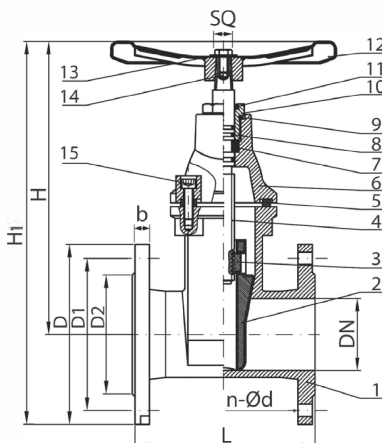

No.	Item	Material
1	Body	EN-GJS-500-7
2	Wedge	EN-GJS-500-7, EPDM
3	Stem nut	Brass
4	Stem	AISI420
5	Sealing gasket	EPDM
6	Bonnet	EN-GJS-500-7
7	Locating ring	Brass
8	Sealing ring	EPDM
9	Sealing ring	EPDM
10	Sealing nut	Brass
11	Sealing ring	EPDM
12	Handwheel	EN-GJS-500-7
13	Washer	AISI304
14	Bolt	AISI304
15	Bolt	AISI304

All illustrations, technical data, dimensions (in mm) and weights (all weights specified in kg) are non-binding and are subject to change

