

ФЛАНЦЕВИЙ ПЕРЕХІДНИК

серія FFR



ТЕХНИЧЕСКИЕ ХАРАКТЕРИСТИКИ

Фланцеві з'єднання згідно з EN1092-2: PN10 / PN16

Розроблено відповідно до EN545

Максимальний робочий тиск: PN16/16 бар

Робоча температура: 0 °C - + 70 °C

Колір RAL5015

Порошкове епоксидне покриття товщиною 250 мкм

Корпус із високоміцного чавуну EN-GJS-500-7 Епоксидне

покриття, сертифіковане WRAS. Сертифіковане ACS

епоксидне покриття за запитом



ФЛАНЦЕВІ ФАСОННІ ЧАСТИНИ

DN1	DN2	Flange drilling	L	e1	e2	Bara, кг	BLUCAST ref. no.	DN1	DN2	Flange drilling	L	e1	e2	Bara, кг	BLUCAST ref. no.
65	50	PN10/16	200	7	7		FFR065050	250	150	PN10	300	9	7.8	26	FFR250150
80	50	PN10/16	200	7	7	5.9	FFR080050	250	150	PN16	300	9	7.8	26	FFRP250150
80	65	PN10/16	200	7	7	6	FFR080065	250	200	PN10	300	9	8.4	29.5	FFR250200
100	50	PN10/16	200	7.2	7	6.8	FFR100050	250	200	PN16	300	9	8.4	29.5	FFRP250200
100	65	PN10/16	200	7.2	7	8.8	FFR100065	300	100	PN10	300	9.6	7.2	30.3	FFR300100
100	80	PN10/16	200	7.2	7	8	FFR100080	300	100	PN16	300	9.6	7.2	30.3	FFRP300100
125	100	PN10/16	200	7.4	7	8.5	FFR125100	300	150	PN10	300	9.6	7.8	32.1	FFR300150
150	50	PN10/16	200	7.8	7	9.7	FFR150050	300	200	PN10	300	9.6	8.4	33	FFR300200
150	65	PN10/16	200	7.8	7	9.8	FFR150065	300	200	PN16	300	9.6	8.4	33	FFRP300200
150	80	PN10/16	200	7.8	7	10	FFR150080	300	250	PN10	300	9.6	9	34	FFR300250
150	100	PN10/16	200	7.8	7.2	10.1	FFR150100	300	250	PN16	300	9.6	9	34	FFRP300250
150	125	PN10/16	200	7.8	7.5	17.2	FFR150125	400	100	PN10	300	10.8	9	51	FFR400100
200	80	PN10	300	8.4	7	17.5	FFR200080	400	150	PN10	300	10.8	9	51	FFR400150
200	80	PN16	300	8.4	7	17.5	FFRP200080	400	200	PN10	300	10.8	9	73.5	FFR400200
200	100	PN10	300	8.4	7.2	21.9	FFR200100	400	250	PN10	300	10.8	9	50	FFR400250
200	100	PN16	300	8.4	7.2	21.9	FFRP200100	400	300	PN10	300	10.8	9	58	FFR400300
200	150	PN10	300	8.4	7.8	22.7	FFR200150	500	300	PN10	300	12	12	110	FFR500300
200	150	PN16	300	8.4	7.8	22.7	FFRP200150	500	400	PN10	300	12	12	94	FFR500400
250	100	PN10	300	9	7.2	24.2	FFR250100	600	300	PN10	400	13.2	13.2	152	FFR600300
250	100	PN16	300	9	7.2	24.2	FFRP250100	600	400	PN10	300	13.2	13.2	142	FFR600400

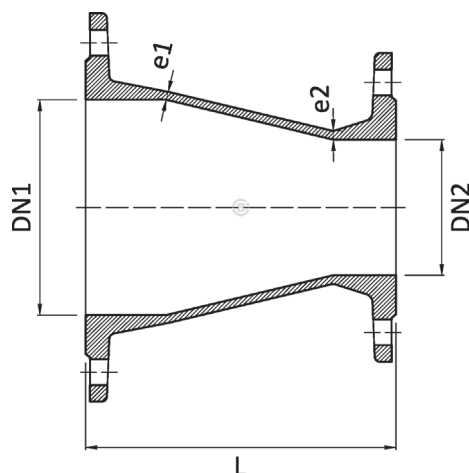

All illustrations, technical data, dimensions (in mm) and weights (all weights specified in kg) are non-binding and are subject to change



BLUCAST

making water accessible

ГИДРОТЕРМ
prom