

ФЛАНЦЕВІ ТРІЙНИКИ

серія Т



ТЕХНІЧНІ ХАРАКТЕРИСТИКИ

Фланцеві кінцеві з'єднання відповідно до EN1092-2: PN10/PN16
 Розроблено відповідно до EN545
 Максимальний робочий тиск: PN16 / 16 бар
 Робоча температура: 0°C - +70°C
 Колір RAL5015
 Порошкове епоксидне покриття товщиною 250 мкм
 Корпус із ковкого чавуну EN-GJS-500-7
 Епоксидне покриття, затверджене WRAS

ФЛАНЦЕВІ ФАСОННІ ЧАСТИНИ

DN1	DN2	Flange drilling	L	H	e1	e2	Bara, кг	BLUCAST ref. no.
50	50	PN10/16	300	150	7	7	9.8	T050050
65	50	PN10/16	330	165	7	7	12	T065050
65	65	PN10/16	330	165	7	7	13	T065065
80	50	PN10/16	310	145	7	7	13	T080050
80	65	PN10/16	330	160	7	7	13.5	T080065
80	80	PN10/16	330	165	7	7	11.9	T080080
100	50	PN10/16	320	165	7.2	7	12.7	T100050
100	65	PN10/16	360	165	7.2	7	13.5	T100065
100	80	PN10/16	330	170	7.2	7	15.4	T100080
100	100	PN10/16	360	180	7.2	7.2	15.3	T100100
150	50	PN10/16	335	175	7.8	7	27.8	T150050
150	65	PN10/16	440	195	7.8	7	28	T150065
150	80	PN10/16	360	200	7.8	7	28.5	T150080
150	100	PN10/16	440	210	7.8	7.2	29.5	T150100
150	150	PN10/16	440	220	7.8	7.8	30.7	T150150
200	50	PN10	365	200	8.4	7	32	T200050
200	65	PN10	365	215	8.4	7	32.8	T200065
200	80	PN10	380	225	8.4	7	30.9	T200080
200	100	PN10	400	230	8.4	7.2	35.5	T200100
200	100	PN16	400	230	8.4	7.2	35.5	TP200100
200	150	PN10	460	245	8.4	7.8	40.5	T200150
200	150	PN16	460	245	8.4	7.8	40.5	TP200150
200	200	PN10	520	260	8.4	8.4	45.4	T200200
200	200	PN16	520	260	8.4	8.4	45.4	TP200200
250	65	PN10	385	260	9	7	45	T250065
250	80	PN10	405	265	9	7	48	T250080
250	100	PN10	425	270	9	7.2	52.6	T250100
250	100	PN16	425	270	9	7.2	52.6	TP250100

DN1	DN2	Flange drilling	L	H	e1	e2	Weight	BLUCAST ref. no.
250	150	PN10	485	280	9	7.8	62	T250150
250	150	PN16	485	280	9	7.8	62	TP250150
250	200	PN10	540	290	9	8.4	64.8	T250200
250	200	PN16	540	290	9	8.4	64.8	TP250200
250	250	PN10	600	300	9	9	89	T250250
250	250	PN16	600	300	9	9	89	TP250250
300	80	PN10	425	295	9.6	7	62	T300080
300	80	PN16	425	295	9.6	7	62	TP300080
300	100	PN10	450	300	9.6	7.2	65	T300100
300	100	PN16	450	300	9.6	7.2	65	TP300100
300	150	PN10	505	310	9.6	7.8	82	T300150
300	150	PN16	505	310	9.6	7.8	82	TP300150
300	200	PN10	565	320	9.6	8.4	85	T300200
300	200	PN16	565	320	9.6	8.4	85	TP300200
300	250	PN10	620	330	9.6	9	90	T300250
300	300	PN10	680	340	9.6	9.6	100.9	T300300
300	300	PN16	680	340	9.6	9.6	100.9	TP300300
400	80	PN10	470	355	10.8	7	91	T400080
400	100	PN10	490	360	10.8	7.2	91	T400100
400	150	PN10	550	370	10.8	7.8	97.5	T400150
400	200	PN10	610	380	10.8	8.4	113.1	T400200
400	250	PN10	665	390	10.8	9	125.1	T400250
400	300	PN10	725	400	10.8	9.6	138.4	T400300
400	400	PN10	840	420	10.8	10.8	163.3	T400400
500	100	PN10	535	400	12	7.2	133.5	T500100
500	150	PN10	600	410	12	7.8	146.6	T500150
500	200	PN10	650	415	12	8.4	157.5	T500200
500	300	PN10	740	450	12	9.6	150	T500300
500	400	PN10	885	480	12	10.8	216.9	T500400
500	500	PN10	1000	500	12	12	252	T500500
600	100	PN10	550	450	13.2	7.2	180.4	T600100
600	150	PN10	650	455	13.2	7.8	203.8	T600150
600	200	PN10	700	460	13.2	8.4	211	T600200
600	300	PN10	810	500	13.2	9.6	250.3	T600300
600	400	PN10	930	530	13.2	10.8	285.8	T600400
600	600	PN10	1100	550	13.2	13.2	355	T600600

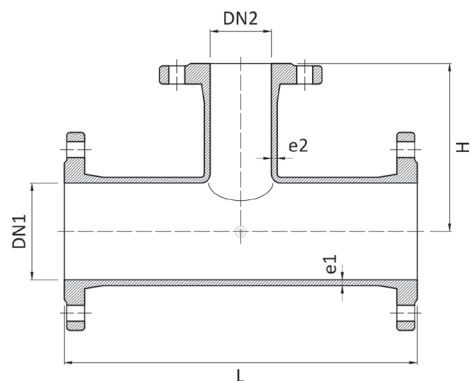

All illustrations, technical data, dimensions (in mm) and weights (all weights specified in kg) are non-binding and are subject to change

