

## ARTICULO: 2460

### Filtro "Y" extremos roscados

### Threaded ends "Y" Strainer

#### Características

1. Filtro "Y".
2. Extremos roscados según ISO 7-1 (EN 10226-1).
3. Construcción en Acero Inox 1.4408 (CF8M).
4. Presión de trabajo máxima 40 bar.
5. Temperatura de trabajo -30 °C + 240 °C.

#### Features

1. "Y" Strainer.
2. Threaded ends according to ISO 7-1 (EN 10226-1).
3. Made of Stainless Steel 1.4408 (CF8M).
4. Max. Working pressure 40 bar.
5. Working temperature -30 °C + 240 °C.

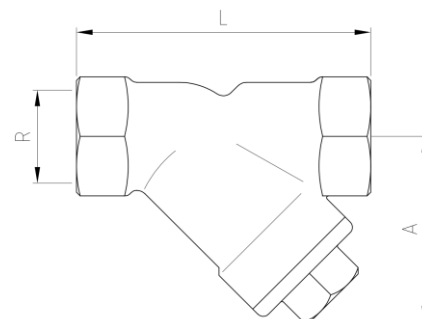
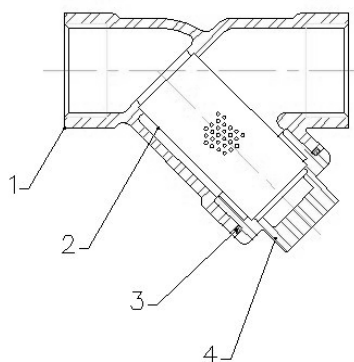

Nº	Denominación / Name	Material	Acabado Superficial / Surface Treatment	Cód. Recambio Spare Part Code
1	Cuerpo / Body	Acero Inox. / Stainless Steel 1.4408	Granallado / Shot blasting	-----
2*	Tamiz / Mesh	Acero Inox. / Stainless Steel AISI 316	-----	2991
3*	Junta / Gasket	PTFE	-----	2991
4	Tapón / Plug	Acero Inox. / Stainless Steel 1.4408	Granallado / Shot blasting	-----

\* Piezas de recambio disponibles / Available spare parts

### DIMENSIONES GENERALES / GENERAL DIMENSIONS

Ref	Medida / Size	PN	Dimensiones / Dimensions (mm)				Peso / Weight (Kg)
			A	L	Ø d	e	
2460 02	1/4"	40	42	65	1	1	0.20
2460 03	3/8"	40	42	65	1	1	0.18
2460 04	1/2"	40	44	65	1	1	0.22
2460 05	3/4"	40	52	80	1	1	0.35
2460 06	1"	40	67	90	1	1	0.58
2460 07	1 1/4"	40	71	105	1	1	0.77
2460 08	1 1/2"	40	82	120	1	1	1.10
2460 09	2"	40	93	140	1	1	1.60

## Detalle de la Malla / Mesh detail:

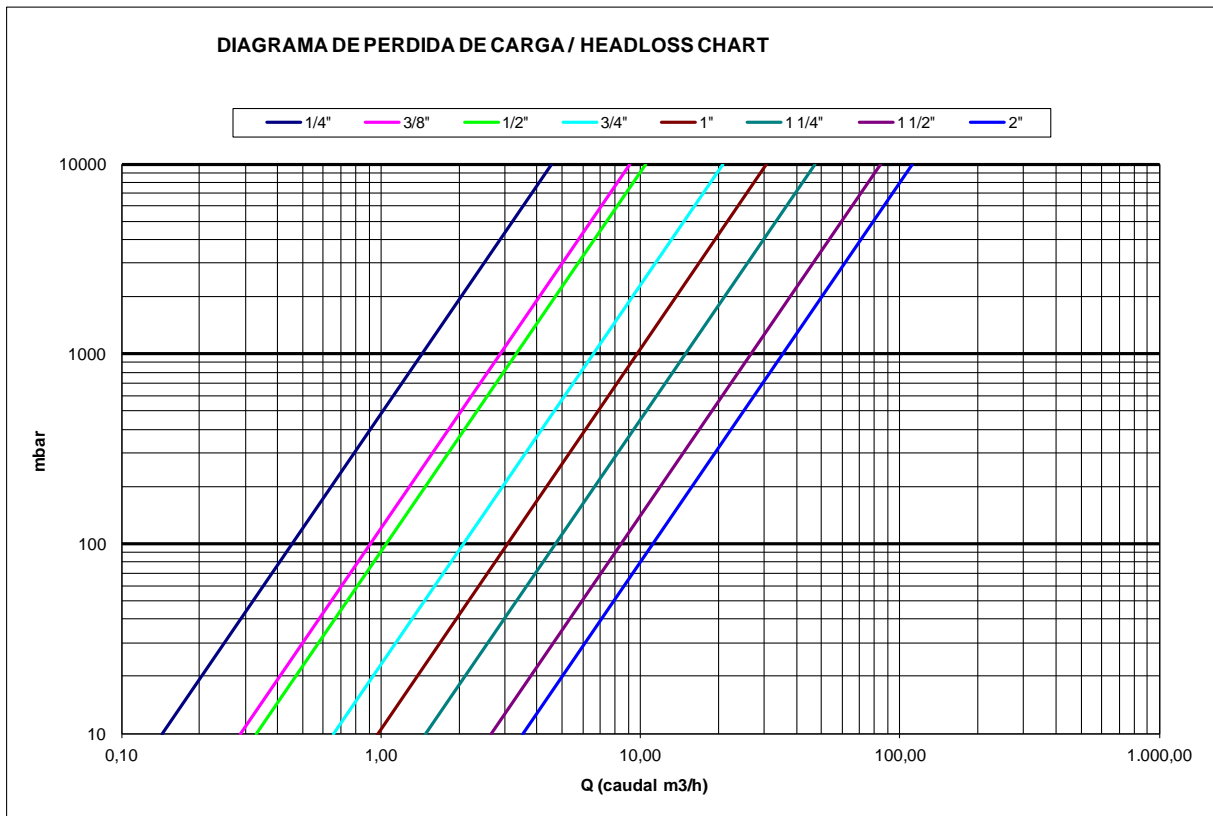
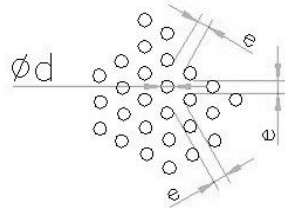

## VALORES DE Kv / Kv VALUES

Kv = Es la cantidad de metros cúbicos por hora (m<sup>3</sup>/h) que pasará a través de la válvula generando una pérdida de carga de 1 bar.

*Kv = Flow rate of water in cubic meter per hour (m<sup>3</sup>/h) that will generate a pressure drop of 1 bar across the valve.*

D	Inch	1/4"	3/8"	1/2"	3/4"	1"	1 1/4"	1 1/2"	2"
Kv	m <sup>3</sup> /h	1,44	2,88	3,30	6,60	9,70	14,90	26,60	35,40

## CURVA PRESION TEMPERATURA / *PRESSURE TEMPERATURE RATING*

